

User's manual

ACS255 drives (0.5...30 hp) (115V-480V Variants)



List of related manuals

Option manuals and guides	Code (English)
<i>ACS255 user's manual for 600V variants</i>	3AXD10000528265
<i>ACS255 user's manual for 115-480V variants</i>	3AXD10000528266

You can find manuals and other product documents in PDF format on the Internet. Go to www.abb.com/drives and select Document Library.

You can browse the library or enter selection criteria, for example a document code, in the search field. For manuals not available in the Document library, contact your local ABB representative

ACS255 drives
0.5...30 hp

User's manual

3AXD10001010247 Rev A
EN
EFFECTIVE: 2019-11-10

1. Table of Contents

1. Table of Contents	5
ACS255 – IP20 (115V) EASY START-UP GUIDE	7
ACS255 – IP66 (115-480V Switched Variants) EASY START-UP GUIDE	8
ACS255 – IP66 (115-480V Non-Switched Variants) EASY START-UP GUIDE	9
2. Safety	11
2.1. What this chapter contains	11
2.2. Use of warnings	11
2.3. Safety in installation and maintenance	11
2.4. Safety in start-up and operation	12
3. General Information and Ratings	14
3.1. Type designation key	14
3.2. Drive Model Numbers – IP20	14
3.3. Drive Model Numbers – IP66	14
4. Mechanical Installation	15
4.1. General	15
4.2. Mechanical Dimensions and Mounting – IP20 Open Units	15
4.3. Guidelines for Enclosure Mounting – IP20 Units	15
4.4. Mechanical Dimensions – IP66 (Nema 4X) Enclosed Units	16
4.5. Guidelines for Mounting Enclosed Units	16
4.6. Gland Plate and Lock Out	17
4.7. Removing the Terminal Cover	17
5. Power Wiring	18
5.1. Grounding the Drive	18
5.2. Wiring Precautions	19
5.3. Connection Diagram	20
5.4. Drive & Motor Connections	21
5.5. Motor Terminal Box Connections	21
5.6. Using the REV/Off/FWD Selector Switch (IP66 Switched Version Only)	22
5.7. Using the Internal Potentiometer (IP66 Switched Version Only)	23
6. Control Wiring	24
6.1. Control Terminal Connections	24
6.2. RJ45 Data Connection	24
7. Operation	25
7.1. Managing the Keypad	25
7.2. Changing Parameters	25
7.3. Resetting to Factory Default Settings	25
8. Quick Start-up and Control	26

8.1.	Motor Control Selection (Advanced Parameter Mode)	26
8.2.	Operating Mode Selection	26
8.3.	Quick Start-up Terminal Control	26
8.4.	Quick Start-up Keypad Control	27
8.5.	Drive Operating Displays.	27
9.	Application Macros	28
9.1.	Overview of macros	28
10.	Parameters	31
10.1.	Parameter Structure	31
10.2.	Parameters in the Short parameter mode	32
10.3.	Read Only Status parameters	34
10.4.	Parameters in the Long parameter mode	36
10.5.	Adjusting the Voltage / Frequency (V/f) characteristics	41
10.6.	Motor Thermistor Connection	41
10.7.	Parameters in the Advanced parameter mode	42
10.8.	Preventing un-authorized parameter editing.	43
11.	Modbus RTU Communications	44
11.1.	Introduction	44
11.2.	Modbus RTU Specification	44
11.3.	RJ45 Connector Configuration	44
11.4.	Modbus Telegram Structure	44
11.5.	Modbus Register Map	44
11.6.	Modbus Parameter Register Map	45
12.	Technical Data	46
12.1.	Environmental	46
12.2.	Rating Tables	46
12.3.	Overload	47
12.4.	Additional Information for UL Compliance	47
12.5.	Derating Information	47
12.6.	Mains Line input Reactors	48
13.	Appendix: Permanent magnet synchronous motors (PMSMs)	49
13.1.	PMSM Motor nameplate data entry.	49
13.2.	PMSM Motor Auto-tune.	49
13.3.	Troubleshooting	49
14.	Trouble Shooting	50
14.1.	Fault Code Messages	50

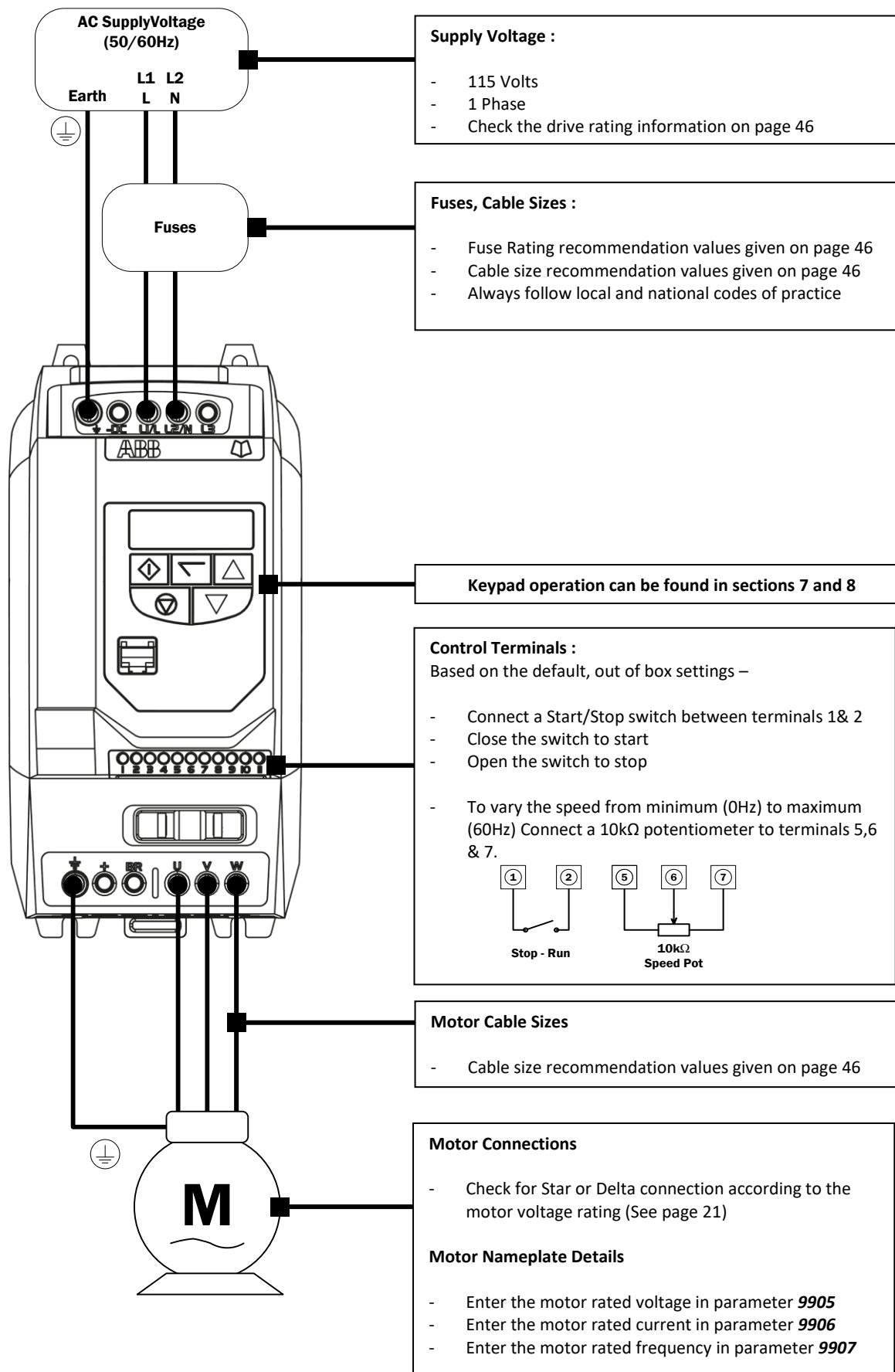

Supply Voltage :

- 115 Volts
- 1 Phase
- Check the drive rating information on page 46

Fuses, Cable Sizes :

- Fuse Rating recommendation values given on page 46
- Cable size recommendation values given on page 46
- Always follow local and national codes of practice

Keypad operation can be found in sections 7 and 8

Control Terminals :
Based on the default, out of box settings –

- Connect a Start/Stop switch between terminals 1& 2
- Close the switch to start
- Open the switch to stop
- To vary the speed from minimum (0Hz) to maximum (60Hz) Connect a 10kΩ potentiometer to terminals 5,6 & 7.

Motor Cable Sizes

- Cable size recommendation values given on page 46

Motor Connections

- Check for Star or Delta connection according to the motor voltage rating (See page 21)

Motor Nameplate Details

- Enter the motor rated voltage in parameter **9905**
- Enter the motor rated current in parameter **9906**
- Enter the motor rated frequency in parameter **9907**

Local Speed Potentiometer

The local speed potentiometer will adjust the output frequency from minimum (Parameter **2007**, default setting = 0Hz) to maximum (Parameter **2008**, default setting = 60Hz)

Run Reverse / Off / Run Forward Switch

With the factory parameter settings, this switch allows the drive to be started in the forward and reverse operating directions. Alternative switch functions can be programmed, such as Local/Remote, hand / Off/ Auto, see page 22.

Local Power disconnect with lock out provision

Mechanical Mounting

- Information can be found on page 16

Keypad operation can be found in section 7 and 8

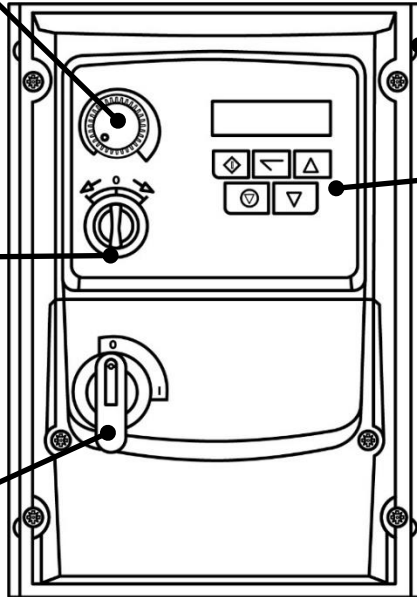

Fuses, Cable Sizes :

- Fuse Rating recommendation values given on page 46
- Cable size recommendation values given on page 46
- Always follow local and national codes of practice.

Supply Voltage :

- 115, 230, 400, 480 Volts
- 1 or 3 Phase
- Check the drive rating information on page 46

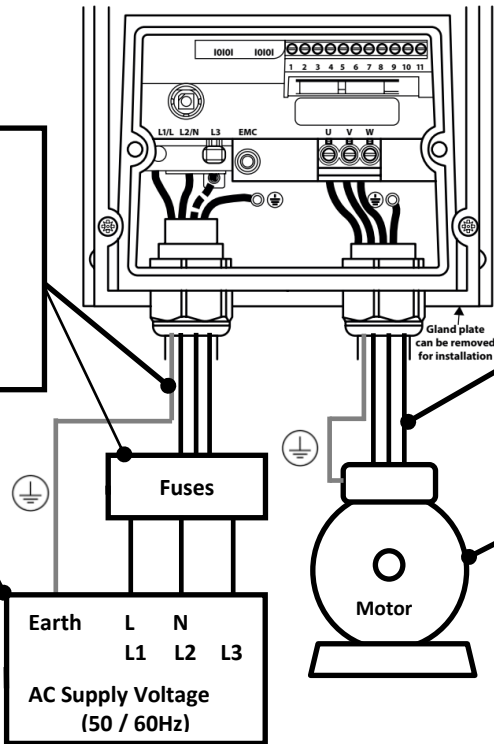

Motor Cable Sizes

- Cable size recommendation values given on page 46

Motor Connections

- Check for Star or Delta connection according to the motor voltage rating (See page 21)

Motor Nameplate Details

- Enter the motor rated voltage in parameter **9905**
- Enter the motor rated current in parameter **9906**
- Enter the motor rated frequency in parameter **9907**

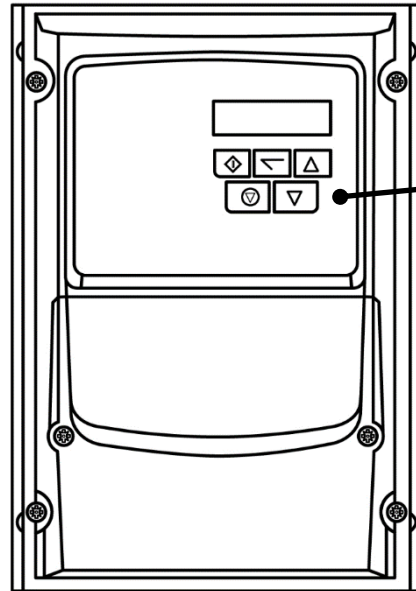

Mechanical Mounting

- Information can be found on page 16

Keypad operation can be found in section 7 and 8

Fuses, Cable Sizes :

- Fuse Rating recommendation values given on page 46
- Cable size recommendation values given on page 46
- Always follow local and national codes of practice.

Supply Voltage :

- 115, 230, 400, 480 Volts
- 1 or 3 Phase
- Check the drive rating information on page 46

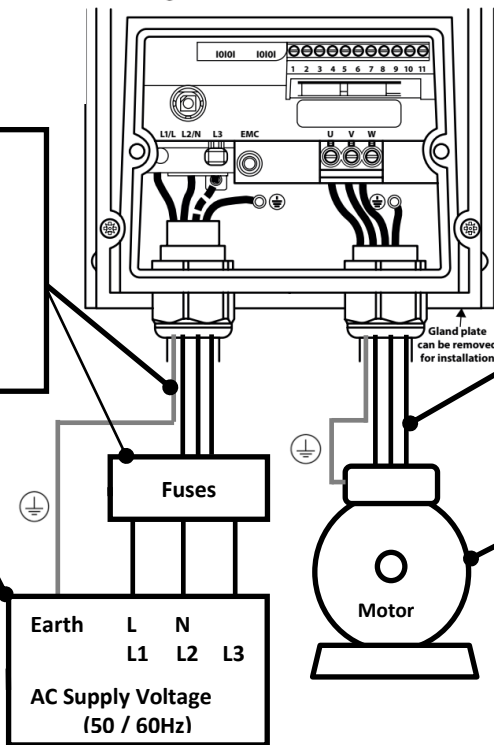

Motor Cable Sizes

- Cable size recommendation values given on page 46

Motor Connections

- Check for Star or Delta connection according to the motor voltage rating (See page 21)

Motor Nameplate Details

- Enter the motor rated voltage in parameter **9905**
- Enter the motor rated current in parameter **9906**
- Enter the motor rated frequency in parameter **9907**

Declaration of Conformity

The manufacturer hereby states that the ACS255 product range conforms to the relevant safety provisions of the following council directives:

2014/30/EU (EMC) and 2014/35/EU (LVD)

2011/65/EU (RoHS)

EN 61800-5-1: 2007	Adjustable speed electrical power drive systems. Safety requirements. Electrical, thermal and energy.
EN 61800-3 2 nd Ed: 2004 / A1:2012	Adjustable speed electrical power drive systems. EMC requirements and specific test methods
EN 55011: 2007	Limits and Methods of measurement of radio disturbance characteristics of industrial, scientific and medical (ISM) radio-frequency equipment (EMC)
EN60529 : 1992	Specifications for degrees of protection provided by enclosures

Electromagnetic Compatibility

All drives are designed with high standards of EMC in mind.

It is the responsibility of the installer to ensure that the equipment or system into which the product is incorporated complies with the EMC legislation of the country of use. Within the European Union, equipment into which this product is incorporated must comply with the EMC Directive 2004/108/EC. When using an ACS255 with an external filter, compliance with the following EMC Categories, as defined by EN61800-3:2004 can be achieved:

Drive Type / Rating	EMC Category		
	First Environment Category C1	First Environment Category C2	Second Environment Category C3
ACS255-__U...	Use External EMC Filter	Use External EMC Filter	Use External EMC Filter
Note	Compliance with EMC standards is dependent on a number of factors including the environment in which the drive is installed, motor switching frequency, motor, cable lengths and installation methods adopted.		
	For shielded motor cable lengths greater than 100m and up to 200m, an output dv/dt filter must be used (please refer to http://www.abb.com/ProductGuide for further details)		

All rights reserved. No part of this User Guide may be reproduced or transmitted in any form or by any means, electrical or mechanical including photocopying, recording or by any information storage or retrieval system without permission in writing from the publisher.

ABB Drives Ltd © 2016

The manufacturer accepts no liability for any damage caused during or resulting from transport, receipt of delivery, installation or commissioning. The manufacturer also accepts no liability for damage or consequences resulting from inappropriate, negligent or incorrect installation, incorrect adjustment of the operating parameters of the drive, incorrect matching of the drive to the motor, incorrect installation, unacceptable dust, moisture, corrosive substances, excessive vibration or ambient temperatures outside of the design specification.

The contents of this User Guide are believed to be correct at the time of printing. In the interest of a commitment to a policy of continuous improvement, the manufacturer reserves the right to change the specification of the product or its performance or the contents of the User Guide without notice.

This User Guide is for use with version 2.02 Software.

User Guide Revision A

This user guide is the “original instructions” document. All non-English versions are translations of the “original instructions”.

The manufacturer adopts a policy of continuous improvement and whilst every effort has been made to provide accurate and up to date information, the information contained in this User Guide should be used for guidance purposes only and does not form the part of any contract.

2. Safety

2.1. What this chapter contains

This chapter contains the safety instructions which you must follow when installing, operating and servicing the drive. If ignored, physical injury or death may follow, or damage may occur to the drive, motor or driven equipment. Read the safety instructions before you work on the unit.

2.2. Use of warnings

Warnings caution you about conditions which can result in serious injury or death and/or damage to the equipment and advice on how to avoid the danger. The following warning symbols are used in this manual:



Electricity warning warns of hazards from electricity which can cause physical injury and/or damage to the equipment.



General warning warns about conditions, other than those caused by electricity, which can result in physical injury and/or damage to the equipment.

2.3. Safety in installation and maintenance

These warnings are intended for all who work on the drive, motor cable or motor.

Electricity safety



WARNING! Ignoring the instructions can cause physical injury or death, or damage to the equipment.

Only qualified electricians are allowed to install and maintain the drive!

- Never work on the drive, motor cable or motor when input power is applied. After disconnecting the input power, always wait for 10 minutes to let the intermediate circuit capacitors discharge before you start working on the drive, motor or motor cable.

Always ensure by measuring with a multimeter (impedance at least 1 Mohm) that:

1. There is no voltage between the drive input phases L1, L2 and L3 and the ground.
2. There is no voltage between terminals + and BR and the ground.

- Do not work on the control cables when power is applied to the drive or to the external control circuits. Externally supplied control circuits may carry dangerous voltage even when the input power of the drive is switched off.
- Do not make any insulation or voltage withstand tests on the drive.
- Be sure the system is properly grounded before applying power. Do not apply AC power before you ensure that all grounding instructions have been followed. Electrical shock can cause serious or fatal injury.

Note:

Even when the motor is stopped, dangerous voltage is present at the power circuit terminals L1, L2, L3 and U, V, W and + and BR.

General safety



WARNING! Ignoring the following instructions can cause physical injury or death, or damage to the equipment.

- The drive is not field repairable. Never attempt to repair a malfunctioning drive; contact your local ABB representative or Authorized Service Centre for replacement.
- Make sure that dust from drilling does not enter the drive during the installation. Electrically conductive dust inside the drive may cause damage or lead to malfunction.
- Ensure sufficient cooling.

2.4. Safety in start-up and operation

These warnings are intended for all who plan the operation, start up or operate the drive.







WARNING! Ignoring the following instructions can cause physical injury or death, or damage to the equipment.

- Before adjusting the drive and putting it into service, make sure that the motor and all driven equipment are suitable for operation throughout the speed range provided by the drive. The drive can be adjusted to operate the motor at speeds above and below the speed provided by connecting the motor directly to the power line.
- Do not activate automatic fault reset functions if dangerous situations can occur. When activated, these functions reset the drive and resume operation after a fault.
- Do not control the motor with an AC contactor or disconnecting device (disconnecting means); use instead the control panel start and stop keys and or external commands (I/O). The maximum allowed number of charging cycles of the DC capacitors (that is, power-ups by applying power) is two per minute.

Note:

- When parameter **1103** PRIMARY COMMAND SOURCE MODE is not set to 1 or 2, the stop key on the control panel will not stop the drive. To stop the drive open terminal 2 of the drive control terminals.
-

	Danger: Indicates a risk of electric shock, which, if not avoided, could result in damage to the equipment and possible injury or death.		Danger: Indicates a potentially hazardous situation other than electrical, which if not avoided, could result in damage to property.
	<p>The ACS255 variable speed drive is intended for professional installation and commissioning into complete equipment or systems as part of a fixed installation. If installed incorrectly it may present a safety hazard. The ACS255 uses high voltages and currents, carries a high level of stored electrical energy, and is used to control mechanical plant that may cause injury. Close attention is required to system design and electrical installation to avoid hazards in either normal operation or in the event of equipment malfunction. Only qualified electricians are allowed to install and maintain this product.</p> <p>System design, installation, commissioning and maintenance must be carried out only by personnel who have the necessary training and experience. They must carefully read this safety information and the instructions in this Guide and follow all information regarding transport, storage, installation and use of the ACS255, including the specified environmental limitations.</p> <p>Do not perform any flash test or voltage withstand test on the ACS255. Any electrical measurements required should be carried out with the ACS255 disconnected.</p> <p>Electric shock hazard! Disconnect and ISOLATE the ACS255 before attempting any work on it. High voltages are present at the terminals and within the drive for up to 10 minutes after disconnection of the electrical supply. Always ensure by using a suitable multimeter that no voltage is present on any drive power terminals prior to commencing any work.</p> <p>Where supply to the drive is through a plug and socket connector, do not disconnect until 10 minutes have elapsed after turning off the supply.</p> <p>Ensure correct grounding connections. The ground cable must be sufficient to carry the maximum supply fault current which normally will be limited by the fuses. Suitably rated fuses should be fitted in the mains supply to the drive, according to any local legislation or codes.</p> <p>Do not carry out any work on the drive control cables when power is applied to the drive or to the external control circuits.</p>		
	<p>Within the European Union, all machinery in which this product is used must comply with the Machinery Directive 2006/42/EC, Safety of Machinery. In particular, the machine manufacturer is responsible for providing a main switch and ensuring the electrical equipment complies with EN60204-1.</p> <p>The level of integrity offered by the ACS255 control input functions – for example stop/start, forward/reverse and maximum speed is not sufficient for use in safety-critical applications without independent channels of protection. All applications where malfunction could cause injury or loss of life must be subject to a risk assessment and further protection provided where needed.</p> <p>The driven motor can start at power up if the enable input signal is present.</p> <p>The STOP function does not remove potentially lethal high voltages. ISOLATE the drive and wait 10 minutes before starting any work on it. Never carry out any work on the Drive, Motor or Motor cable when the input power is still applied.</p> <p>The ACS255 can be programmed to operate the driven motor at speeds above or below the speed achieved when connecting the motor directly to the mains supply. Obtain confirmation from the manufacturers of the motor and the driven machine about suitability for operation over the intended speed range prior to machine start up.</p> <p>Do not activate the automatic fault reset function on any systems whereby this may cause a potentially dangerous situation.</p> <p>The ACS255 has an Ingress Protection rating of IP20 or IP66 depending on the model. IP20 units must be installed in a suitable enclosure.</p> <p>ACS255s are intended for indoor use only.</p> <p>When mounting the drive, ensure that sufficient cooling is provided. Do not carry out drilling operations with the drive in place, dust and metal shavings from drilling may lead to damage.</p> <p>The entry of conductive or flammable foreign bodies should be prevented. Flammable material should not be placed close to the drive</p> <p>Relative humidity must be less than 95% (non-condensing).</p> <p>Ensure that the supply voltage, frequency and number of phases correspond to the rating of the ACS255 as delivered.</p> <p>Never connect the mains power supply to the Output terminals U, V, W.</p> <p>Do not install any type of automatic switchgear between the drive and the motor</p> <p>Wherever control cabling is close to power cabling, maintain a minimum separation of 4 in. (100 mm) and arrange crossings at 90 degrees</p> <p>Ensure that all terminals are tightened to the appropriate torque setting</p> <p>Do not attempt to carry out any repair of the drive. In the case of suspected fault or malfunction, contact your local ABB representative for further assistance.</p>		

3. General Information and Ratings

This chapter contains information about the ACS255 including how to identify the drive.

3.1. Type designation key

The type designation contains information on the specification and configuration of the drive. You find the type designation label attached to the drive. The first digits from the left express the basic configuration, for example ACS255-03U-05A8-4.

The explanations of the type designation label selections are described below.

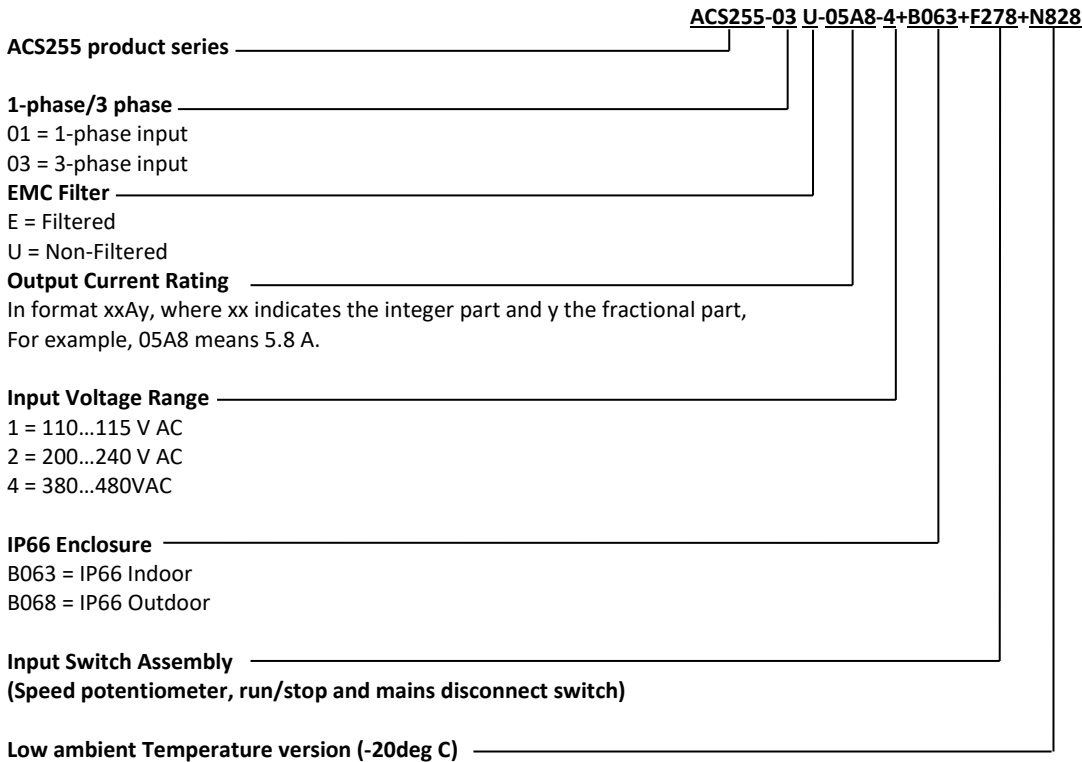

3.2. Drive Model Numbers – IP20

Mechanical Dimensions and Mounting information are shown in section 4.
Further Electrical Specifications are shown in section 12.2.

Model Number	Power (HP)	Output Current (A)	Input switch assembly	Internal DB transistor	Frame Size
1-phase 110V...115V AC (+/-10%) - 3 Phase 230V Output					
ACS255-01U-02A3-1	0.5	2.3	No	No	E1
ACS255-01U-04A3-1	1	4.3	No	No	E1
ACS255-01U-05A8-1	1.5	5.8	No	Yes	E2

3.3. Drive Model Numbers – IP66

Mechanical Dimensions and Mounting information are shown in section 4.
Further Electrical Specifications are shown in section 12.2.

Model Number	Power (HP)	Output Current (A)	Input switch assembly	Internal DB transistor	Frame Size
3-phase 200...240V AC (+/-10%) - 3 Phase Output					
ACS255-03U-24A0-2+B068	7.5	24	No	Yes	E3
ACS255-03U-24A0-2+B068+F278	7.5	24	Yes	Yes	E3
ACS255-03U-30A0-2+B068	10	30	No	Yes	E4
ACS255-03U-30A0-2+B068+F278	10	30	Yes	Yes	E4
ACS255-03U-46A0-2+B068	15	46	No	Yes	E4
ACS255-03U-46A0-2+B068+F278	15	46	Yes	Yes	E4
3-phase 380...480V AC (+/-10%) - 3 Phase Output					
ACS255-03U-24A0-4+B068	15	24	No	Yes	E3
ACS255-03U-24A0-4+B068+F278	15	24	Yes	Yes	E3
ACS255-03U-30A0-4+B068	20	30	No	Yes	E4
ACS255-03U-30A0-4+B068+F278	20	30	Yes	Yes	E4
ACS255-03U-39A0-4+B068	25	39	No	Yes	E4
ACS255-03U-39A0-4+B068+F278	25	39	Yes	Yes	E4
ACS255-03U-46A0-4+B068	30	46	No	Yes	E4
ACS255-03U-46A0-4+B068+F278	30	46	Yes	Yes	E4

4. Mechanical Installation

4.1. General

- Carefully Unpack the ACS255 and check for any signs of damage. Notify the shipper immediately if any exist.
- Check the drive rating label to ensure it is of the correct type and power requirements for the application.
- Store the ACS255 in its box until required. Storage should be clean and dry and within the temperature range -40°C to +60°C
- The ACS255 should be mounted in a vertical position only on a flat, flame resistant vibration free mounting using the integral holes.
- The ACS255 must be installed in a pollution degree 1 or 2 environment only.
- Do not mount flammable material close to the ACS255
- Ensure that the minimum cooling air gaps, as detailed in sections 4.3 and 4.5 are left clear
- Ensure that the ambient temperature range does not exceed the permissible limits for the ACS255 given on page 46.
- Provide suitable clean, moisture and contaminant free cooling air sufficient to fulfil the cooling requirements of the ACS255 according to sections 4.3 and 12.1.

4.2. Mechanical Dimensions and Mounting – IP20 Open Units

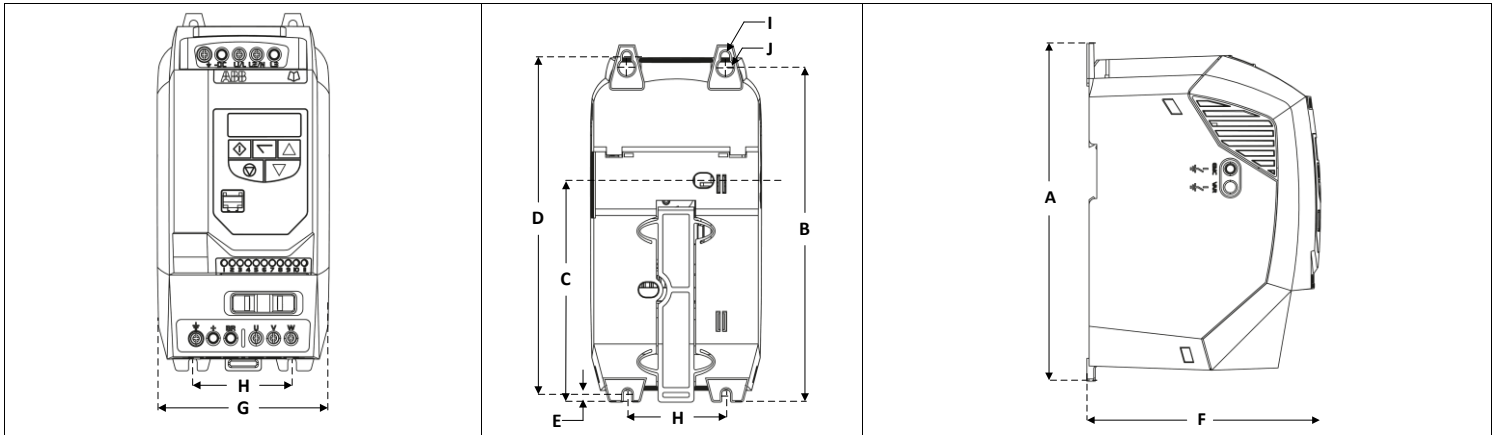

Drive Frame Size	A		B		C		D		E		F		G		H		I		J		Weight	
	mm	in	mm	in	mm	in	mm	in	mm	in	mm	in	mm	in	mm	in	mm	in	mm	in	Kg	lb
1	173	6.81	160	6.30	109	4.29	162	6.38	5	0.20	123	4.84	82	3.23	50	1.97	5.5	0.22	10	0.39	1.0	2.20
2	221	8.70	207	8.15	137	5.39	209	8.23	5.3	0.21	150	5.91	109	4.29	63	2.48	5.5	0.22	10	0.39	1.7	3.75

NOTE Maximum Control Terminal Torque Settings of 0.5 Nm (4.5 lb-in)
Maximum Power Terminal Torque Settings of 1 Nm (9 lb-in)

4.3. Guidelines for Enclosure Mounting – IP20 Units

- Installation should be in a suitable enclosure, according to EN60529 or other relevant local codes or standards.
- Enclosures should be made from a thermally conductive material.
- Where vented enclosures are used, there should be free space clearance above and below the drive to ensure good air circulation – see the diagram below for minimum free space clearance. Air should be drawn in below the drive and expelled above the drive.
- In any environments where the conditions require it, the enclosure must be designed to protect the ACS255 against ingress of airborne dust, corrosive gases or liquids, conductive contaminants (such as condensation, carbon dust, and metallic particles) and sprays or splashing water from all directions.
- High moisture, salt or chemical content environments should use a suitably sealed (non-vented) enclosure.

The enclosure design and layout should ensure that the adequate ventilation paths and clearances are left to allow air to circulate through the drive heatsink. ABB Drives recommend the following minimum mounting clearance requirements for drives mounted in non-ventilated metallic enclosures:-

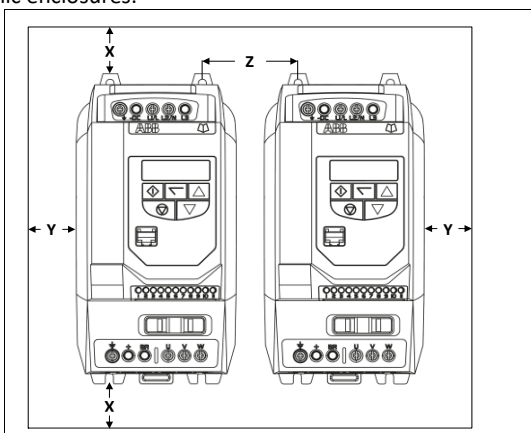

Drive Size	X Above & Below		Y Either Side		Z Between	
	mm	in	mm	in	mm	in
1	50	1.97	50	1.97	33	1.30
2	75	2.95	50	1.97	46	1.81

Note :
Dimension Z assumes that the drives are mounted side-by-side with no clearance.

Typical drive heat losses are 3% of operating load conditions.

Above are guidelines only and the operating ambient temperature of the drive MUST be maintained at all times.

4.4. Mechanical Dimensions – IP66 (Nema 4X) Enclosed Units

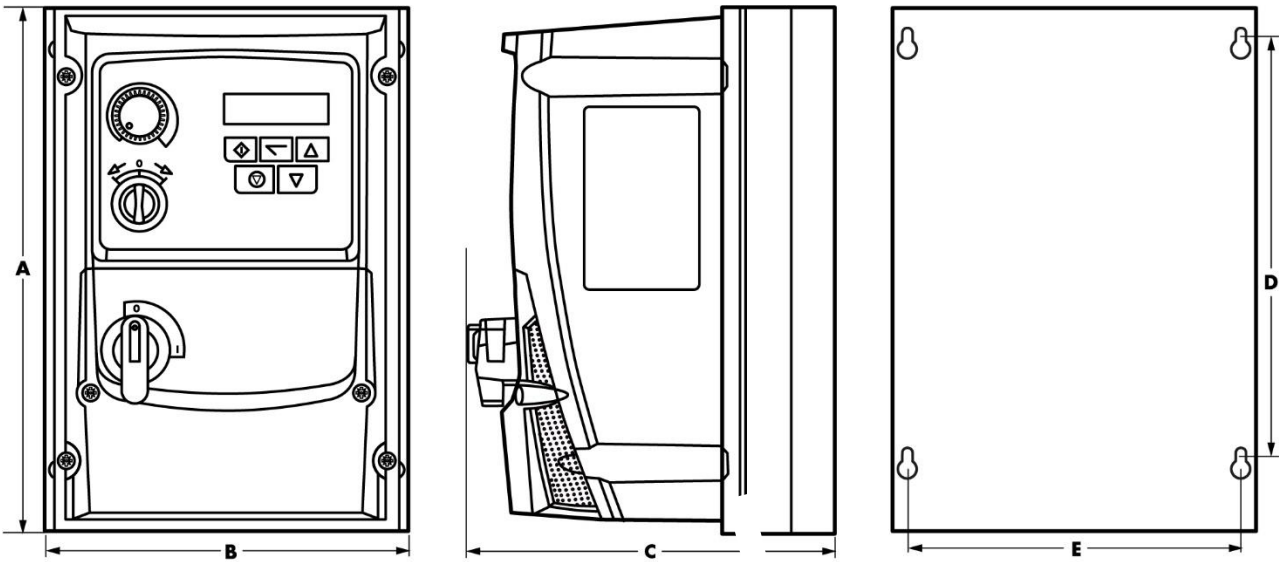

Drive Frame Size	A		B		C		D		E		Weight	
	mm	in	mm	in	mm	in	mm	in	mm	in	kg	lb
3	310.0	12.2	210.5	8.29	238	9.37	251.5	9.90	197.5	7.78	7.0	15.4
4	360.0	14.17	240	9.45	275	10.83	300.0	11.08	226.0	8.89	9.5	20.9

NOTE The size 3 and 4 product has 4 symmetrical mounting points
 Maximum Control Terminal Torque Settings of 0.5 Nm (4.5 lb-in)
 Maximum Power Terminal Torque Settings of 1 Nm (9 lb-in) / Size 4 = 4.1 Nm (36.5 lb-in)

4.5. Guidelines for Mounting Enclosed Units

- Before mounting the drive, ensure that the chosen location meets the environmental condition requirements for the drive shown in section 12.1
- The drive must be mounted vertically, on a suitable flat surface
- The minimum mounting clearances as shown in the table below must be observed
- The mounting site and chosen mountings should be sufficient to support the weight of the drives
- The Enclosed ACS255s can be installed side-by-side with their heatsink flanges touching. This gives adequate ventilation space between drives.
- If the ACS255 is to be installed above another drive or any other heat-producing device, the minimum vertical spacing (X) is 150mm (5.9 inches) above and below.

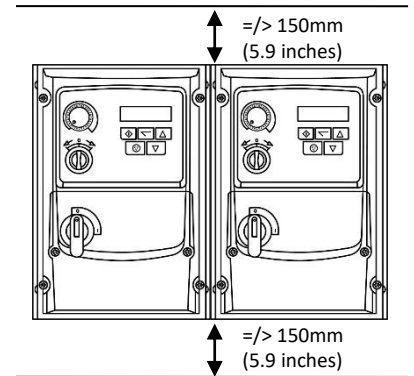

4.6. Gland Plate and Lock Out

The use of a suitable gland system is required to maintain the appropriate IP / Nema rating. The gland plate has pre moulded cable entry holes for power and motor connections suitable for use with glands as shown in the following table. Where additional holes are required, these can be drilled to suitable size. Please take care when drilling to avoid leaving any particles within the product.

Cable Gland recommended Hole Sizes & types:		
	Moulded Hole Size	UL Gland Size
Frame Size 3	1.11in (28.2mm)	PG21
Frame Size 4	Power Entries: 1.11in (28.2mm)	PG21
	Control Entry : 0.87in (22mm)	PG16

- UL rated ingress protection ("Type ") is only met when cables are installed using a UL recognized bushing or fitting for a flexible-conduit system which meets the required level of protection ("Type")
- For conduit installations the conduit entry holes require standard opening to the required sizes specified per the NEC.
- Not intended for rigid conduit system

Local Power Isolator Lock out

On the switched models the Local Power Isolator switch can be locked in the 'Off' position using a 20mm standard shackle padlock (not supplied).

IP66 / Nema 4X Unit Lock Out

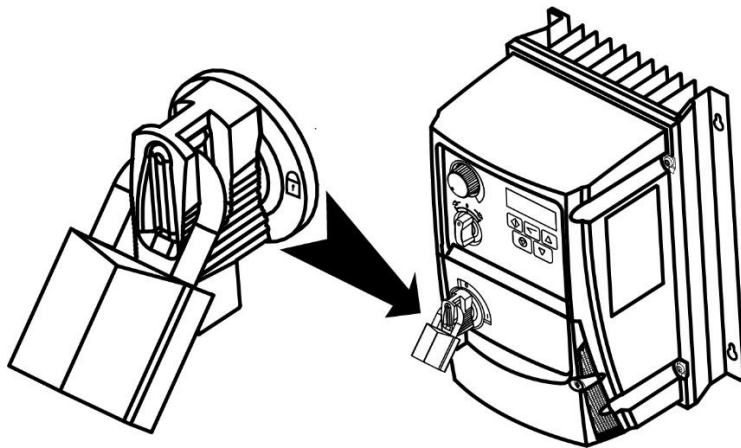

4.7. Removing the Terminal Cover

To access the connection terminals, the drive front cover needs to be removed as shown.



IP66 / NEMA 4X Units

Removing the 2 screws on the front of the product allows access to the connection terminals, as shown below.



5. Power Wiring

5.1. Grounding the Drive

	This manual is intended as a guide for proper installation. ABB Drives Ltd cannot assume responsibility for the compliance or the non-compliance to any code, national, local or otherwise, for the proper installation of this drive or associated equipment. A hazard of personal injury and/or equipment damage exists if codes are ignored during installation.
	This ACS255 contains high voltage capacitors that take time to discharge after removal of the main supply. Before working on the drive, ensure isolation of the main supply from line inputs. Wait ten (10) minutes for the capacitors to discharge to safe voltage levels. Failure to observe this precaution could result in severe bodily injury or loss of life.
	Only qualified electrical personnel familiar with the construction and operation of this equipment and the hazards involved should install, adjust, operate, or service this equipment. Read and understand this manual and other applicable manuals in their entirety before proceeding. Failure to observe this precaution could result in severe bodily injury or loss of life.

5.1.1. Recommended installation for EMC compliance

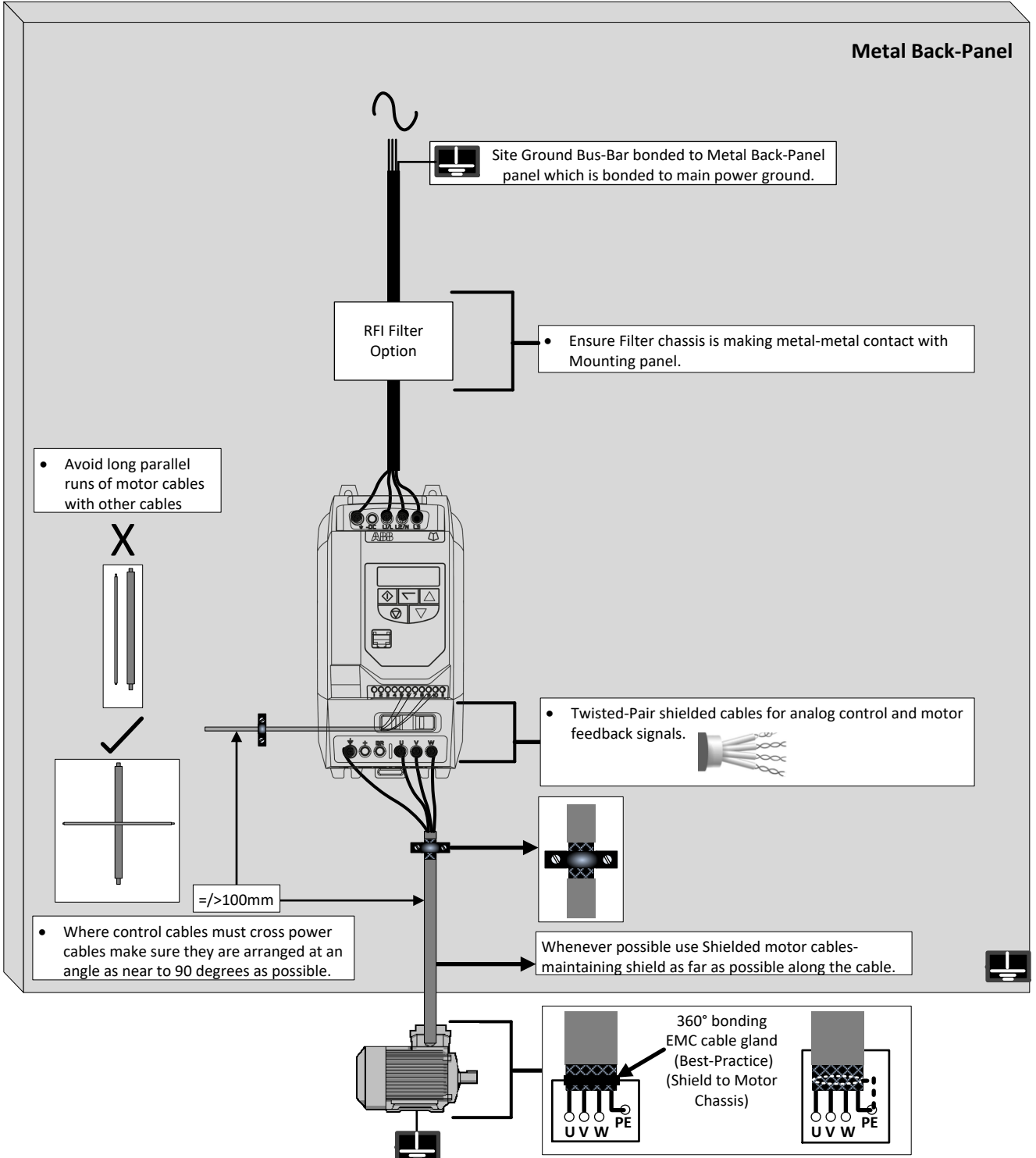

5.1.2. Grounding Guidelines

The ground terminal of each ACS255 should be individually connected DIRECTLY to the site ground bus bar (through the filter if installed). ACS255 ground connections should not loop from one drive to another, or to, or from any other equipment. Ground loop impedance must confirm to local industrial safety regulations. To meet UL regulations, UL approved ring crimp terminals should be used for all ground wiring connections.

The drive Safety Ground must be connected to system ground. Ground impedance must conform to the requirements of national and local industrial safety regulations and/or electrical codes. The integrity of all ground connections should be checked periodically.

When installing the drive on any power supply where the phase-ground voltage may exceed the phase-phase voltage (typically IT supply networks or Marine vessels) it is essential that the internal EMC filter ground and surge protection varistor ground (where fitted) are disconnected. If in doubt, refer to your Local ABB representative for further information.

5.1.3. Protective Earth Conductor

The Cross sectional area of the PE Conductor must be at least equal to that of the incoming supply conductor.

5.1.4. Safety Ground

This is the safety ground for the drive that is required by code. One of these points must be connected to adjacent building steel (girder, joist), a floor ground rod, or bus bar. Grounding points must comply with national and local industrial safety regulations and/or electrical codes.

The safety ground terminal provides a grounding point for the motor cable shield. The motor cable shield connected to this terminal (drive end) should also be connected to the motor frame (motor end). Use a shield terminating or EMI clamp to connect the shield to the safety ground terminal.

5.1.5. Motor Ground

The motor ground must be connected to one of the ground terminals on the drive.

5.1.6. Ground Fault Monitoring

As with all inverters, a leakage current to earth can exist. The ACS255 is designed to produce the minimum possible leakage current while complying with worldwide standards. The level of current is affected by motor cable length and type, the effective switching frequency, the earth connections used and the type of RFI filter installed. If a GFCI (Ground Fault Current interrupter) is to be used, the following conditions apply: -

- The device must be suitable for protecting equipment with a DC component in the leakage current
- Individual GFCI's should be used for each ACS255

The ACS255 product range has input supply voltage surge suppression components fitted to protect the drive from line voltage transients, typically originating from lightning strikes or switching of high power equipment on the same supply.

5.2. Wiring Precautions

Connect the ACS255 according to sections 5.3 and 5.4, ensuring that motor terminal box connections are correct. There are two connections in general: Star and Delta. It is essential to ensure that the motor is connected in accordance with the voltage at which it will be operated. For more information, refer to section 0.

Type MC continuous corrugated aluminium armor cable with symmetrical grounds or shielded power cable is recommended for the motor cables if metallic conduit is not used.

The power cables must be rated for 75°C (167°F).

5.2.1. EMC Filters



WARNING! EMC filters should not be used when there is a risk that the phase to earth voltage could exceed the phase to phase voltage, Typically IT (ungrounded) or Marine vessels and corner-grounded TN systems, otherwise this may cause danger or damage to the EMC filter.

5.3. Connection Diagram

5.3.1. IP66 (Nema 4X) Switched Units

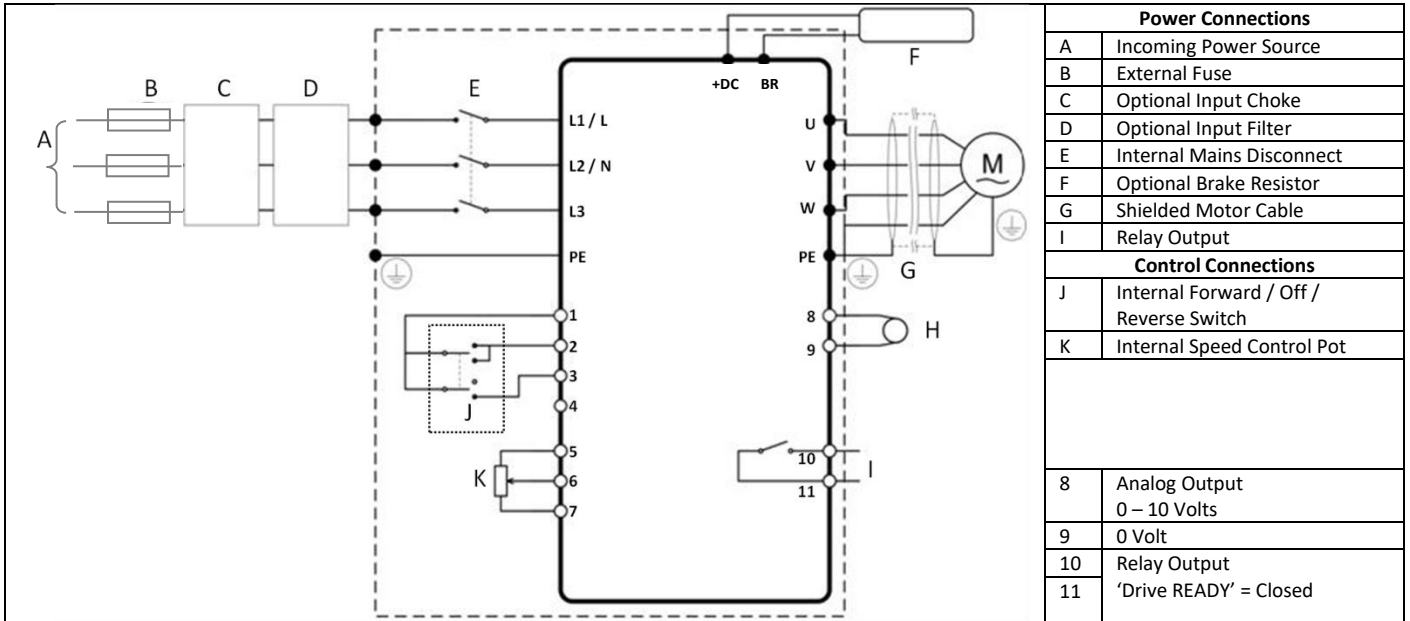

5.3.2. IP20 & IP66 (Nema 4X) Non- Switched Units

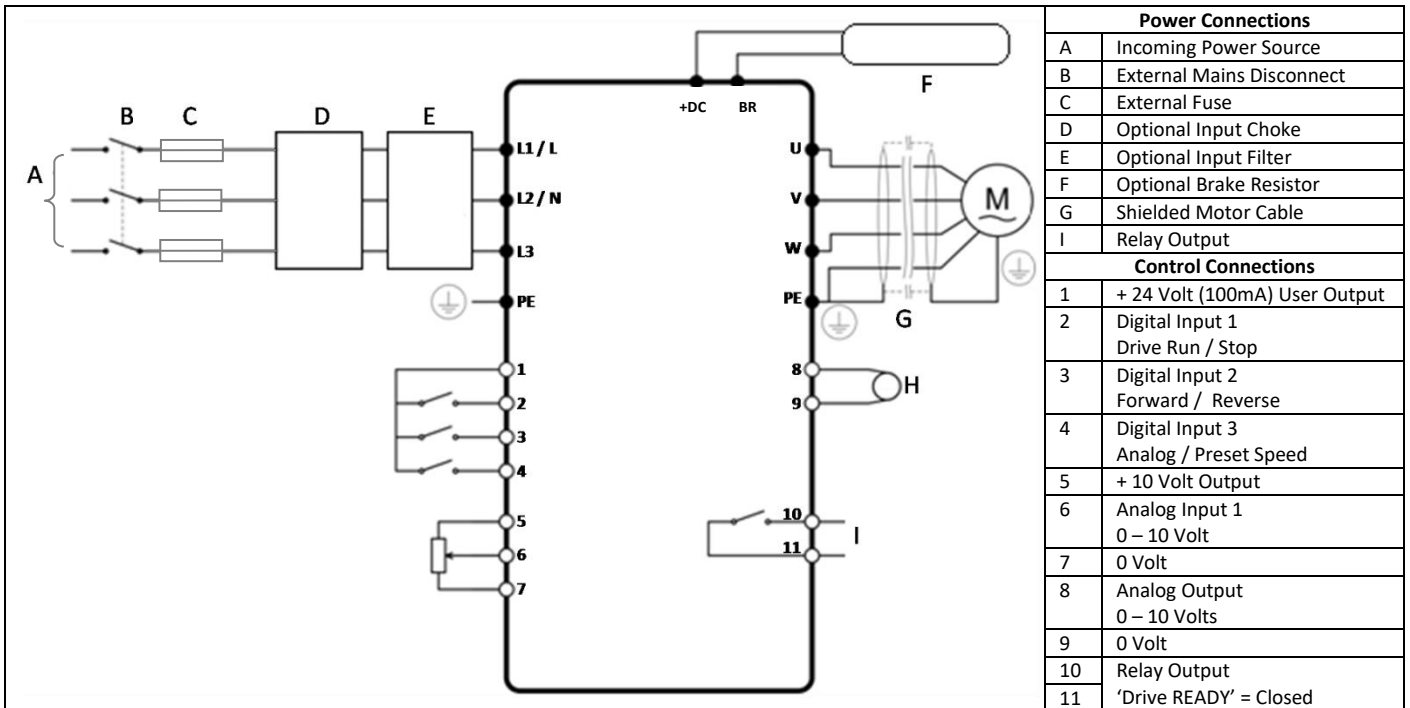

5.4. Drive & Motor Connections

For 1 phase supply, power should be connected to L1/L, L2/N. For 3 phase supplies power should be connected to L1, L2, L3. Phase sequence is not important. The Motor should be connected to U, V, W

For drives that have a dynamic brake transistor an optional external braking resistor will need be connected to +DC and BR when required.

The brake resistor circuit should be protected by a suitable thermal protection circuit. The “-DC”, “+” and “BR” connections are blanked off by plastic tabs when sent from the factory. The plastic tabs can be removed if/when required.

Single phase supply

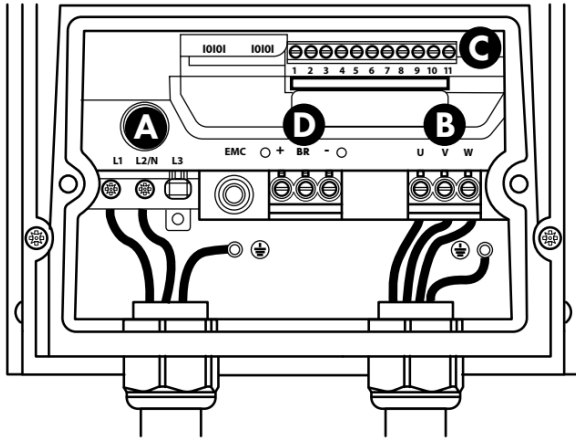

3 phase supply

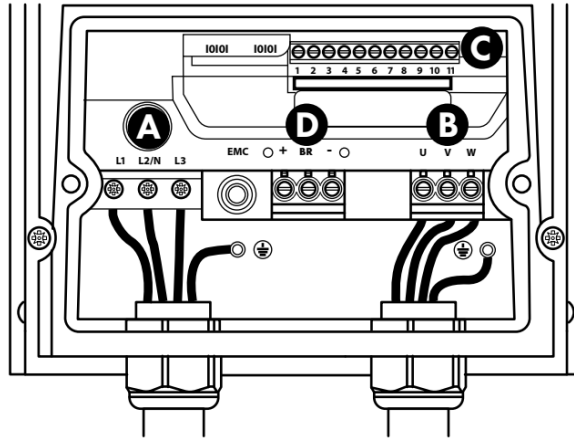

5.5. Motor Terminal Box Connections

Most general purpose motors are wound for operation on dual voltage supplies. This is indicated on the nameplate of the motor. This operational voltage is normally selected when installing the motor by selecting either STAR or DELTA connection. STAR always gives the higher of the two voltage ratings. Example Motor nameplate shown below (380V Delta illustrated):

ABB Motors										
3 ~ motor M2AA 200 MLA 4										
IEC 200 M/L 55										
No										
Ins.cl. F IP 55										
V	Hz	kW	r/min	A	cos φ	IΔ/IN	T	E/s		
690 Y	50	30	1475	32.5	0.83					
400 D	50	30	1475	56	0.83					
660 Y	50	30	1470	34	0.83					
380 D	50	30	1470	59	0.83					380 V Mains Voltage
415 D	50	30	1475	54	0.83					
440 D	60	35	1770	59	0.83					
Cat. no 3GAA 202 001 - ADA										
6312/C3 6210/C3 180 kg										
IEC 34-1										

5.6. Using the REV/Off/FWD Selector Switch (IP66 Switched Version Only)

By adjusting the parameter settings the ACS255 can be configured for multiple applications and not just for Forward or Reverse.

This could typically be for Hand/Off/Auto applications (also known as Local/Remote) for HVAC and pumping industries.

The integrated switch operates in parallel with drive terminal 2 (T2) and terminal 3 (T3) as digital input 1 and digital input 2.

By default, the integrated switch is enabled.

If required, the built in control switch may be disabled using the following method:

Switch Position						
Switch Left		Switch Centre		Switch Right		
DI1	DI2	DI1	DI2	DI1	DI2	
1	1	0	0	0	1	Lc-Off
0	0	0	0	0	0	Lc-On
0	1	0	0	1	0	Alert

NOTE The table below applies to default setting "Lc-Off"

Switch Position			Parameters to Set		Notes	
Switch Left	Switch Centre	Switch Right	1103	9902		
Run Reverse	STOP	Run Forward	0	0	Factory Default Configuration Run Forward or Reverse with speed controlled from the Local POT	
STOP	STOP	Run Forward	0	5,7	Run forward with speed controlled from the local POT Run Reverse - disabled	
Preset Speed 1	STOP	Run Forward	0	1	Run Forward with speed controlled from the Local POT Preset Speed 1 provides a 'Jog' Speed set in parameter 1202	
Run Reverse	STOP	Run Forward	0	6, 8	Run Forward or Reverse with speed controlled from the Local POT	
Run in Auto	STOP	Run in Hand	0	4	Run in Hand – Speed controlled from the Local POT Run in Auto 0 Speed controlled using Analog input 2 e.g. from PLC with 4-20mA signal.	
Run in Speed Control	STOP	Run in PI Control	5	1	In Speed Control the speed is controlled from the Local POT In PI Control, Local POT controls PI set point	
Run in Preset Speed Control	STOP	Run in PI Control	5	0, 2, 4,5, 8..12	In Preset Speed Control, parameter 1202 sets the Preset Speed In PI Control, POT can control the PI set point (Parameter 4010 =1)	
Run in Hand	STOP	Run in Auto	3	6	Hand – speed controlled from the Local POT Auto – Speed Reference from Modbus	
Run in Hand	STOP	Run in Auto	3	3	Hand – Speed reference from Preset Speed 1 (Parameter 1202) Auto – Speed Reference from Modbus	

5.7. Using the Internal Potentiometer (IP66 Switched Version Only)

On switched drives, the built in pot (indicated) may be used to directly control the signal level applied to analog input 1, and therefore the output frequency (motor speed).

To select the built in pot as the signal source for analog input 1, set **1300** = "i n-Pot"

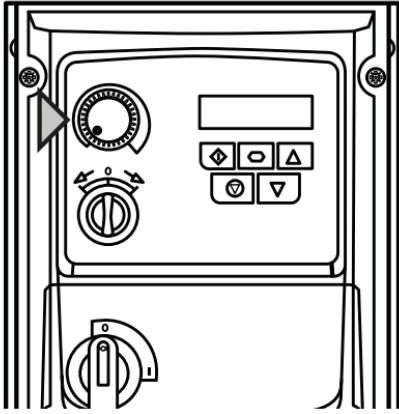

6. Control Wiring

6.1. Control Terminal Connections

Default Connections	Control Terminals			Description
	1	+24V	+24V Output	+24V, 100mA.
	2	DI1	Digital Input 1	Positive logic "Logic 1" input voltage range: 8V ... 30V DC "Logic 0" input voltage range: 0V ... 4V DC
	3	DI2	Digital Input 2	
	4	DI/AI 3	Digital/Analog Input 3	Digital: 8 to 30V Analog: 0 to 10V, 0 to 20mA or 4 to 20mA
	5	+10V	+10V Output	+10V, 10mA, 1kΩ minimum
	6	DI/AI4	Digital/Analog Input 4	Analog: 0 to 10V, 0 to 20mA or 4 to 20mA Digital: 8 to 30V
	7	COM	0V	User ground connected to terminal 9
	8	AO	Analog Output / Digital Output	Analog: 0 to 10V, 20mA maximum Digital: 0 to 24V
	9	AGND	0V	User ground connected to terminal 7
	10	ROC	Relay Common	
	11	RNO	Relay Contact	Contact 255Vac, 6A / 30Vdc, 5A

6.2. RJ45 Data Connection

For MODBUS RTU register map information please refer to page 44

When using MODBUS control the Analog and Digital Inputs can be configured as shown in section 9.1.3

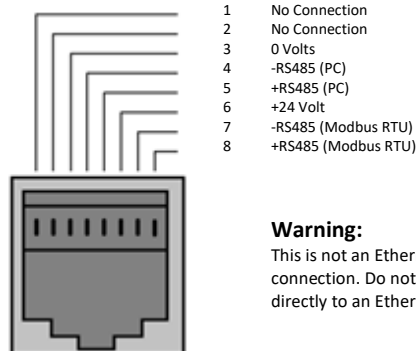

Warning:
This is not an Ethernet connection. Do not connect directly to an Ethernet port.

7. Operation

7.1. Managing the Keypad

The drive is configured and its operation monitored via the keypad and display.

	NAVIGATE	Used to display real-time information, to access and exit parameter edit mode and to store parameter changes. (press for >1 second to toggle between status and parameter mode)
	UP	Used to increase speed in real-time mode or to increase parameter values in parameter edit mode
	DOWN	Used to decrease speed in real-time mode or to decrease parameter values in parameter edit mode
	RESET / STOP	Used to reset a tripped drive. When in Keypad mode is used to Stop a running drive.
	START	When in keypad mode, used to Start a stopped drive or to reverse the direction of rotation if bi-directional keypad mode is enabled

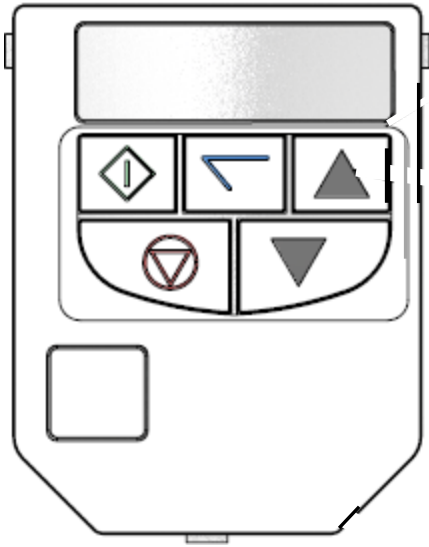

7.2. Changing Parameters

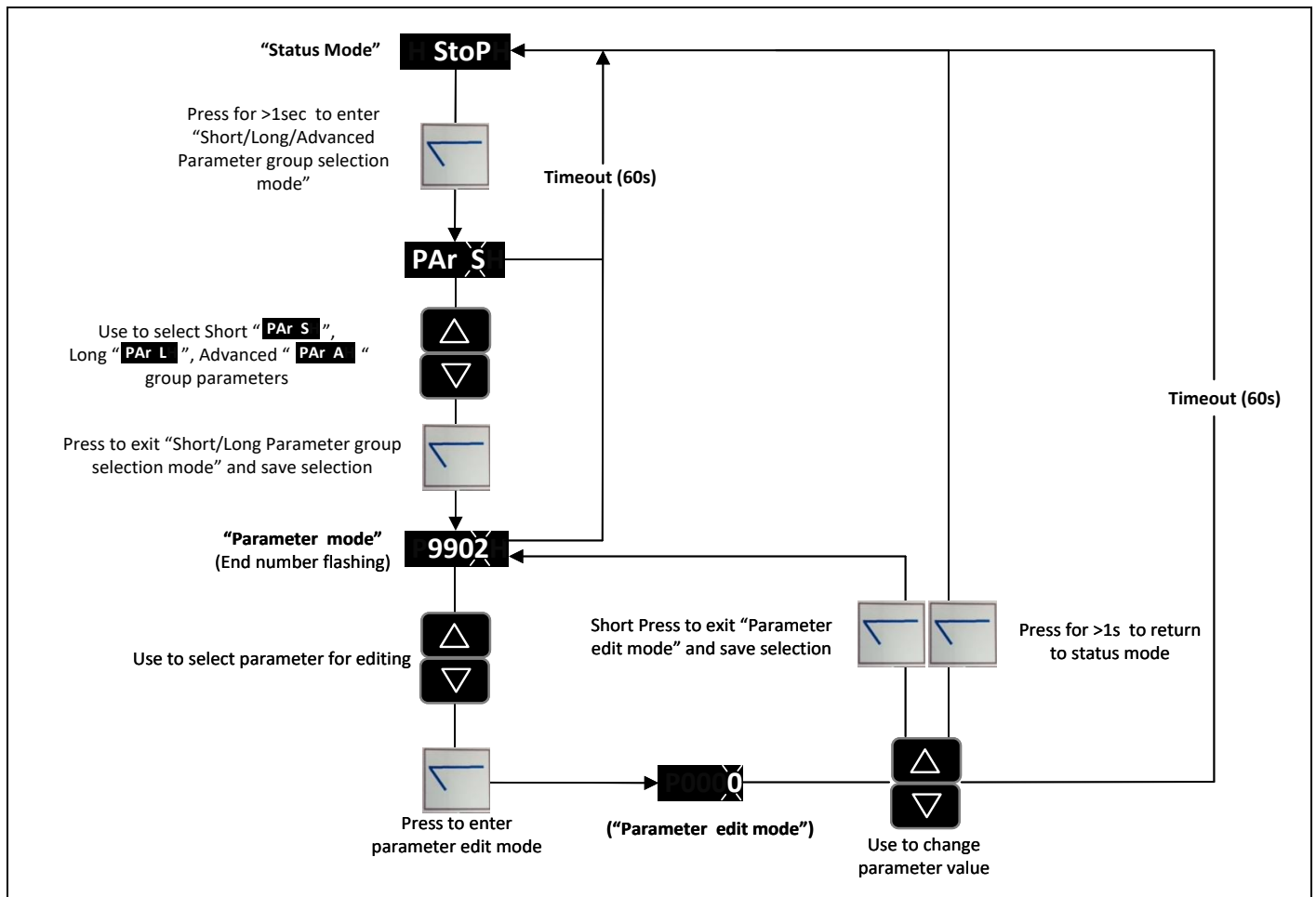

NOTE When attempting to edit a parameter the drive must be stopped (not running), if not "L" will be shown on the left side of the display.

7.3. Resetting to Factory Default Settings

To reset factory default parameters, press , and for >2s. The display shows *P-dEF* . Press the button to acknowledge and reset the drive.

8. Quick Start-up and Control

8.1. Motor Control Selection (Advanced Parameter Mode)

When delivered, the drive is in the factory default state, meaning that it is set to operate in V/f mode. This may yield acceptable performance for variable torque applications like centrifugal pumps and fans or other equipment not subjected to dynamic loads. Vector speed control will provide enhanced performance for constant torque applications like conveyor, mixers, or other applications subjected to dynamic loading.

9903 Motor parameter autotune MUST be performed at first startup when **9903** Vector speed control mode is selected. All PMAC motors are run in PM sensorless vector control.

For most applications using the E4 frame drives, Vector speed control will yield better motor control.





1. Perform Mechanical and Electrical installation as per section 4 and 5. The motor must be connected to the drive.
2. Connect a control switch between the control terminals 1 and 2 ensuring that the contact is open (drive disabled).
3. Navigate to the Advanced parameter menu as shown in 10.1.1 Group Navigation.
4. For Vector speed control mode, select "0" in **9903** Operating Mode Select and select "1" in **9910** Motor parameter autotune. The Autotune function will immediately performs a non-rotating autotune and then returns **9910** to "0"
5. Proceed with Operating Mode Select (Macros)

8.2. Operating Mode Selection

Setup can be simplified by selecting the operating mode for the drive in **2605** Operating Mode Select. This function provides a quick set up to configure key parameters to the intended application of the drive. Parameters **2017** Current Limit, **2610** & **2611** Torque Characteristic, and **2101** Spin Start are preset according to the table on page 42.

8.3. Quick Start-up Terminal Control

When delivered, the drive is in the factory default state, meaning that it is set to operate in terminal control mode (Parameter **9902** DIGITAL INPUTS FUNCTION SELECT = 0 and **1103** PRIMARY COMMAND SOURCE MODE = 0) and all parameters have the default values as indicated in section 10.

1. Perform Mechanical and Electrical installation as per section 4 and 5.
2. Connect a control switch between the control terminals 1 and 2 ensuring that the contact is open (drive disabled).
3. Connect a potentiometer (1kΩ min to 10 kΩ max) between terminals 5 and 7, and the wiper to terminal 6.
4. With the potentiometer set to zero, switch on the supply to the drive. The display will show $StOP$.
5. Press and hold the navigate key for >1s to enter parameter view mode and enter motor data from motor nameplate into parameter **9905** MOTOR RATED VOLTAGE, **9906** MOTOR RATED CURRENT, and parameter **9907** MOTOR RATED FREQUENCY. Enter the rated RPM (nameplate) of the motor in **9908** MOTOR RATED SPEED to allow the display of the estimated motor speed.
6. Close the control switch, terminals 1-2. The drive is now 'enabled' and the output frequency/speed are controlled by the potentiometer. The display shows zero speed in Hz ($H \ 0.0$) with the potentiometer turned to minimum. If the display is not showing Hz, change it using the  (Navigate) key.
7. Turn the potentiometer to maximum. The motor will accelerate to 60Hz (the default value of parameter **2008** MAXIMUM FREQUENCY / SPEED LIMIT) under the control of the accelerating ramp time parameter **2202** ACCELERATION RAMP TIME. The display shows 60Hz ($H \ 60.0$) at max speed.
8. To display motor current (A), briefly press the  (Navigate) key.
9. To display estimated motor speed (RPM), briefly press the  (Navigate) key a second time. (Motor nameplate speed (RPM) must be entered in **9908** Motor Rated Speed to display the estimated RPM).
10. To display power (Hp) briefly press the  (Navigate) key a third time.
11. Press  again to return to speed (Hz) display.

To stop the motor, either turn the potentiometer back to zero or disable the drive by opening the control switch (terminals 1-2).

If the enable/disable switch is opened the drive will decelerate to stop at which time the display will show $StOP$. If the potentiometer is turned to zero with the enable/disable closed the display will show $H \ 0.0$ (0.0Hz), if left like this for 60 seconds the drive will go into standby mode, display shows $Stndby$, waiting for a speed reference signal.

8.4. Quick Start-up Keypad Control

To allow the ACS255 to be controlled from the keypad in a forward direction only, set parameter 1103 PRIMARY COMMAND SOURCE MODE =1:

1. Perform Mechanical and Electrical installation as per section 4 and 0.
2. Connect a control switch between the control terminals 1 and 2 ensuring that the contact is open (drive disabled).
3. Switch on the supply to the drive, Press and hold the navigate key for > 1 to enter parameter view mode and set parameter 1103 Primary Command Source Mode = 1
4. Enable the drive by closing the switch between control terminals 1 & 2. The display will show $StoP$.
5. Press the \diamond key. The display shows $H 0.0$. If the display is not showing Hz, change it using the \square (Navigate) key.
6. Press \triangle to increase speed.
7. The drive will run forward, increasing speed until \triangle is released.



The rate of acceleration is controlled by the setting of parameter 2202 ACCELERATION RAMP TIME, check this before starting.

8. Press ∇ to decrease speed. The drive will decrease speed until ∇ is released. The rate of deceleration is limited by the setting in 2203 DECELERATION RAMP TIME.
9. Press the \blacktriangledown key. The drive will decelerate to rest at the rate set in parameter 2203 DECELERATION RAMP TIME.
10. The display will finally show $StoP$ at which point the drive is disabled
11. To preset a target speed prior to enable, press the \blacktriangledown key while the drive is stopped. The display will show the target speed, use the \triangle & ∇ keys to adjust as required then press the \blacktriangledown key to return the display to $StoP$.
12. Pressing the \diamond key will start the drive accelerating to the target speed.

To allow the ACS255 to be controlled from the keypad in a forward and reverse direction, set parameter 1103 PRIMARY COMMAND SOURCE MODE =2:

13. Operation is the same as when parameter 1103 PRIMARY COMMAND SOURCE MODE =1 for start, stop and changing speed.
14. Press the \diamond key. The display changes to $H 0.0$.
15. Press \triangle to increase speed
16. The drive will run forward, increasing speed until \triangle is released. Acceleration is limited by the setting in parameter 2202 ACCELERATION RAMP TIME. The maximum speed is the speed set in parameter 2008 MAXIMUM FREQUENCY / SPEED LIMIT.
17. To reverse the direction of rotation of the motor, press the \diamond key again.

8.5. Drive Operating Displays.

$StoP$	Drive mains power applied, but no Enable or Run signal applied	
$H 0.0$	Drive running, display shows output frequency (Hz)	Whilst the drive is running, the following displays can be selected by briefly pressing the \square button on the drive. Each press of the button will cycle the display through to the next selection.
$A 0.0$	Drive running, display shows motor current (Amps)	
$P 0.0$	Drive Running, display shows motor power (kW)	
$Stndby$	If the enable/disable switch is opened the drive will decelerate to stop at which time the display will show $StoP$. If the potentiometer is turned to zero with the enable/disable closed the display will show $H 0.0$. (0.0Hz), if left like this for 60 seconds the drive will go into standby mode, display shows $Stndby$, waiting for a speed reference signal.	

9. Application Macros

9.1. Overview of macros

Application macros are pre-programmed parameter sets. While starting up the drive, the user selects the macro best suited for the purpose with parameter **9902** DIGITAL INPUTS FUNCTION SELECT and **1103** PRIMARY COMMAND SOURCE MODE.

1103 (control Mode)	Selected Speed Reference
0 : Terminal Mode	Analog input 1
1 : Keypad Mode (uni-directional)	Digital Potentiometer
2 : Keypad Mode (bi-directional)	Digital Potentiometer
4 : Fieldbus Control	Speed reference via Fieldbus
5 : User PI mode	PI controller output

9.1.1. Terminal Mode 1103 PRIMARY COMMAND SOURCE MODE = 0.

9902	Digital input 1 (T2)	Digital input 2 (T3)	Digital input 3 (T4)	Analog input (T6)	Comments
0	Open: Stop (disable) Closed: Run (enable)	Open : Forward run Closed : Reverse run	Open : Analog speed ref Closed : Preset speed 1	Analog input 1 reference	
1	Open: Stop (disable) Closed: Run (enable)	Open: Analog speed ref Closed : Preset speed 1/2	Open: Preset speed 1 Closed : Preset speed 2	Analog input 1 reference	
2	Open: Stop (disable) Closed: Run (enable)	Digital Input 2	Digital Input 3	Preset Speed	Open: Preset speeds 1-4 Closed : Max Speed (parameter 2008)
		Open	Open	Preset Speed 1	
		Closed	Open	Preset Speed 2	
		Open	Closed	Preset Speed 3	
		Closed	Closed	Preset Speed 4	
3	Open: Stop (disable) Closed: Run (enable)	Open : Analog speed ref Closed : Preset speed 1	External trip input : Open: Trip, Closed: Run	Analog input 1 reference	Connect external motor thermistor PTC type or similar to digital input 3
4	Open: Stop (disable) Closed: Run (enable)	Open : Analog input 1 Closed : Analog input 2	Analog input 2 reference	Analog input 1 reference	Switches between analog inputs 1 and 2
5	Open: Fwd Stop Closed: Fwd Run	Open: Reverse Stop Closed: Reverse Run	Open : Analog speed ref Closed : Preset speed 1	Analog input 1 reference	Closing digital inputs 1 and 2 together carries out a fast stop (Parameter 2206)
6	Open: Stop (disable) Closed: Run (enable)	Open : Forward Closed : Reverse	External trip input : Open: Trip, Closed: Run	Analog input 1 reference	Connect external motor thermistor PTC type or similar to digital input 3
7	Open: Stop (disable) Closed: Fwd Run (enable)	Open: Stop (disable) Closed: Rev Run (enable)	External trip input : Open: Trip, Closed: Run	Analog input 1 reference	Closing digital inputs 1 and 2 together carries out a fast stop (Parameter 2206)
8	Open: Stop (disable) Closed: Run (enable)	Open : Forward Closed : Reverse	Digital Input 3	Analog Input 1	Preset Speed
			Open	Open	Preset Speed 1
			Closed	Open	Preset Speed 2
			Open	Closed	Preset Speed 3
			Closed	Closed	Preset Speed 4
9	Open: Stop (disable) Closed: Forward Run (enable)	Open: Stop (disable) Closed: Reverse Run (enable)	Digital Input 3	Analog Input 1	Preset Speed
			Open	Open	Preset Speed 1
			Closed	Open	Preset Speed 2
			Open	Closed	Preset Speed 3
			Closed	Closed	Preset Speed 4
10	Normally Open (NO) Momentary close to run	Normally Closed (NC) Momentary open to stop	Open : Analog speed ref Closed: Preset speed 1	Analog input 1 reference	
11	Normally Open (NO) Momentary close to run	Normally Closed (NC) Momentary open to stop	Normally Open (NO) Momentary close to rev	Analog input 1 reference	Closing digital inputs 1 and 3 together carries out a fast stop (Parameter 2206)
12	Open: Stop (disable) Closed: Run (enable)	Open: Fast Stop (disable) Closed: Run (enable)	Open : Analog speed ref Closed : Preset speed 1	Analog input 1 reference	
NOTE	Negative Preset Speeds will be inverted if Run Reverse selected				

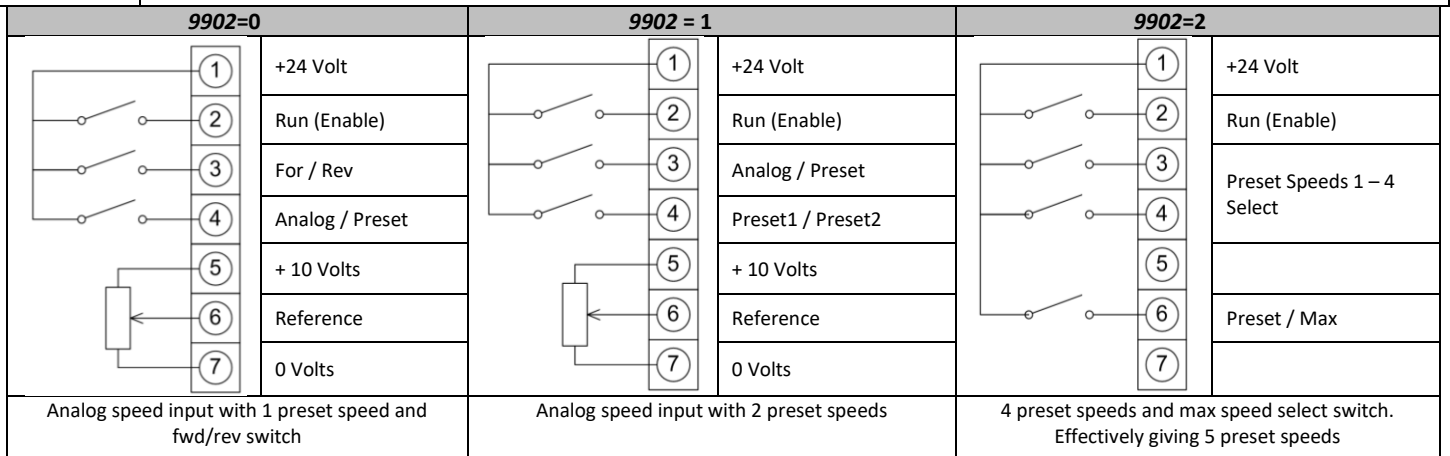

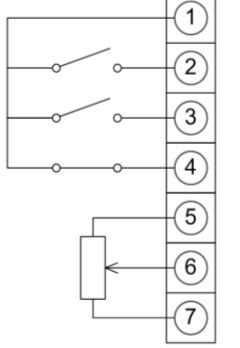
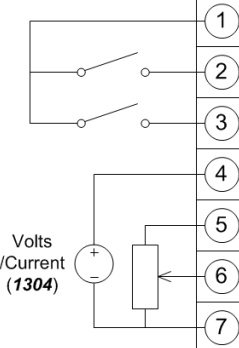
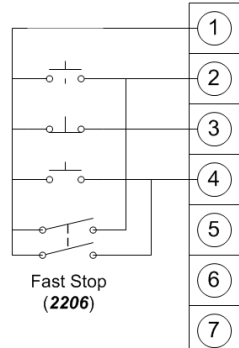
9902=3	9902=4	9902=11
		
+24 Volt Run (Enable) Analog / Preset 1 External Trip + 10 Volts Reference 0 Volts	+24 Volt Run (Enable) Local / Remote (Hand / Auto) Remote (Auto) Reference + 10 Volts Local (Hand) Reference 0 Volts	+24 Volt Run Forward Stop Run Reverse + 10 Volts Reference 0 Volts
Analog speed input with 1 preset speed and motor thermistor trip	Local or remote analog speeds (2 analog inputs)	Push button fwd/rev/stop with fast stop using 2 nd deceleration ramp

9.1.2. Keypad Mode 1103 PRIMARY COMMAND SOURCE MODE = 1 or 2.

9902	Digital input 1 (T2)	Digital input 2 (T3)	Digital input 3 (T4)	Analog input (T6)	Comments
0, 1, 5, 8..12	Open: Stop (disable) Closed: Run (enable)	Closed : remote UP push-button	Closed : remote DOWN push-button	Open : Forward +24V : Reverse	
2	Open: Stop (disable) Closed: Run (enable)	Closed : remote UP push-button	Closed : remote DOWN push-button	Open : Keypad speed ref +24V : Preset speed 1	
3	Open: Stop (disable) Closed: Run (enable)	Closed : remote UP push-button	External trip input : Open: Trip, Closed: Run	Closed : remote DOWN push-button	Connect external motor thermistor PTC type or similar to digital input 3
4	Open: Stop (disable) Closed: Run (enable)	Closed : remote UP push-button	Open : Keypad speed ref Closed : Analog input 1	Analog input 1	
6	Open: Stop (disable) Closed: Run (enable)	Open : Forward run Closed : Reverse run	External trip input : Open: Trip, Closed: Run	Open : Keypad speed ref +24V : Preset speed 1	Connect external motor thermistor PTC type or similar to digital input 3
7	Open: Forward Stop Closed: Forward Run	Open: Reverse Stop Closed: Reverse Run	External trip input : Open: Trip, Closed: Run	Open : Keypad speed ref +24V : Preset speed 1	Closing digital inputs 1 and 2 together carries out a fast stop (2206)

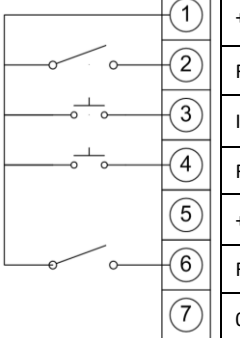
9902=0	
	+24 Volt Run (Enable) Increase Speed Reduce Speed + 10 Volts Forward / Reverse 0 Volts
Remote push button speed control with fwd/rev	

NOTE By default if the enable signal is present the drive will not Enable until the START button is pressed. To automatically enable the drive when the enable signal is present set Parameter 1100 KEYPAD MODE RESTART FUNCTION = 2 or 3. This then disables the use of the START & STOP buttons

9.1.3. Modbus Control Mode 1103 PRIMARY COMMAND SOURCE MODE = 4.

9902	Digital input 1 (T2)	Digital input 2 (T3)	Digital input 3 (T4)	Analog input (T6)	Comments
0..2, 4..5, 8..12	Open: Stop (disable) Closed: Run (enable)	No effect	No effect	No effect	Run and stop commands given via the RS485 link and Digital input 1 must be closed for the drive to run.
3	Open: Stop (disable) Closed: Run (enable)	Open : Master speed ref Closed : Preset speed 1	External trip input : Open: Trip, Closed: Run	No effect	Connect external motor thermistor PTC type or similar to digital input 3
6	Open: Stop (disable) Closed: Run (enable)	Open : Master speed ref Closed : Analog input	External trip input : Open: Trip, Closed: Run	Analog input reference	Master Speed Ref - start and stop controlled via RS485. Keypad Speed Ref - drive auto runs if digital input 1 closed, depending on Parameter 1100 setting
7	Open: Stop (disable) Closed: Run (enable)	Open : Master speed ref Closed : keypad speed ref	External trip input : Open: Trip, Closed: Run	No effect	

For further information on the MODBUS RTU Register Map information and communication setup please refer to section 11.

9.1.4. PI Mode 1103 PRIMARY COMMAND SOURCE MODE = 5.

9902	Digital input 1 (T2)	Digital input 2 (T3)	Digital input 3 (T4)	Analog input (T6)	Comments
0, 2, 9..12	Open: Stop (disable) Closed: Run (enable)	Open : PI control Closed : Preset speed 1	PI feedback analog input	Analog input 1	Analog Input 1 can provide an adjustable PI setpoint, by setting Parameter 4010 = 1
1	Open: Stop (disable) Closed: Run (enable)	Open : PI control Closed : Analog input 1	PI feedback analog input	Analog input 1	Analog Input 1 can provide an adjustable PI setpoint, by setting Parameter 4010 = 1
3, 7	Open: Stop (disable) Closed: Run (enable)	Open : PI control Closed : Preset speed 1	External trip input : Open: Trip, Closed: Run	PI feedback analog input	Connect external motor thermistor PTC type or similar to digital input 3
4	Normally Open (NO) Momentary close to run	Normally Closed (NC) Momentary open to stop	PI Feedback Analog Input	Analog Input 1	Normally Open (NO) Momentary close to run
5	Normally Open (NO) Momentary close to run	Normally Closed (NC) Momentary open to stop	Open: PI Control Closed: Preset Speed 1	PI Feedback Analog Input	Normally Open (NO) Momentary close to run
6	Normally Open (NO) Momentary close to run	Normally Closed (NC) Momentary open to stop	Open: External Trip Closed: Run	PI Feedback Analog Input	Normally Open (NO) Momentary close to run
8	Open: Stop (disable) Closed: Run (enable)	Open : Forward run Closed : Reverse run	PI feedback analog input	Analog input 1	Analog Input 1 can provide an adjustable PI setpoint, by setting Parameter 4010 = 1

PI Mode 1103=5, 9902=0	PI Mode 1103=5, 9902=1	PI Mode 1103=5, 9902=3
Remote closed loop PI feedback control with Local Preset speed 1	Remote closed loop PI feedback control with Local Analog speed input	Remote closed loop PI feedback control with Local Preset speed 1 and motor thermistor trip

NOTE By default the PI reference is set for a digital reference level set in Parameter 4011 PI DIGITAL REFERENCE (SETPOINT). When using an Analog reference set Parameter 4010 PI DIGITAL REFERENCE (SETPOINT = 1 (analog) and connect reference signal to analog input 1 (T6). The default settings for proportional gain (parameter 4001), integral gain (Parameter 4002) and feedback mode (Parameter 4005) are suitable for most fan and pump applications. The analog reference used for PI controller can also be used as the local speed reference when parameter 9902 DIGITAL INPUTS FUNCTION SELECT =1.

10. Parameters

10.1. Parameter Structure

The parameters within the drive are split into 3 groups, group 1 is titled "Short Parameter mode" displayed as "Par S" on the drive display, group 2 is titled "Long Parameter mode" displayed as "Par L" on the drive display and group 3 is titled "Advanced Parameter mode" displayed as "Par A".

- "Par S" group brings together the most commonly used parameters to aid quick setup.
- "Par L" group includes all of the drive parameters (except those in "Par-A" group).
- "Par A" group includes the drives advanced functions.

10.1.1. Group Navigation.

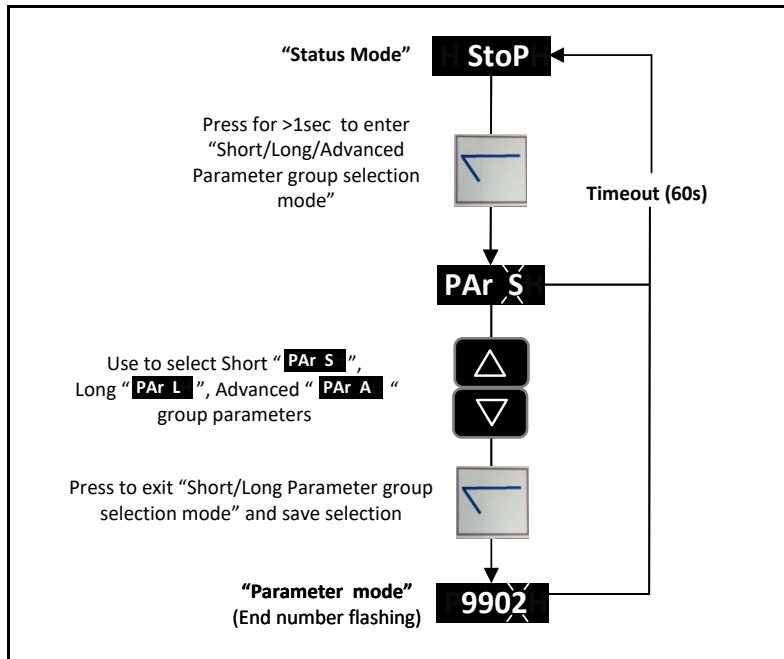

10.1.2. Parameter Structure table.

PAR S	PAR L	PAR A
Parameter No.	Parameter No.	Parameter No.
9902	0000	2017
9905	0401	2105
9906	1100	2106
9907	1103	2301
0401	1202	2605
1103	1203	9903
1202	1204	9910
1203	1205	11201
1204		11203
1301		11206
2008	3400	
2102	4001	
2202	4002	
	4005	
	4010	
	4011	
	4016	
	5302	
	9902	
	9905	
	9906	
	9907	
	9908	

10.2. Parameters in the Short parameter mode

The following table describes the parameters that are visible in the Short parameter mode. See page 25 for how to select the parameter mode. All parameters are presented in detail in section 10.4.



Parameters in the Short parameter mode			
No.	Name/Value	Description	Def
99 START-UP DATA			
Application macros.			
9902	DIGITAL INPUTS FUNCTION SELECT	Defines the function of the digital inputs depending on the control mode setting in Parameter 1103 PRIMARY COMMAND SOURCE MODE. See Application macros on page 28.	1
9905	MOTOR RATED VOLTAGE	This parameter should be set to the rated (nameplate) voltage of the motor (Volts).	Drive Rating Dependent
	110V/230V rated drives 0...255V	Voltage	
	400V rated drives 0...500V	Note : The stress on the motor insulation is always dependent on the drive supply voltage. This also applies in the case where the motor voltage rating is lower than the rating of the drive and the supply of the drive.	
9906	MOTOR RATED CURRENT	This parameter should be set to the rated (nameplate) current of the motor.	Drive Rating Dependent
	0.2*drive rated output current...1.0*drive rated output current	Current	
9907	MOTOR RATED FREQUENCY	This parameter should be set to the rated (nameplate) frequency of the motor	60Hz
	25...500Hz	Frequency	
04 FAULT HISTORY			
Fault history (read only)			
0401	TRIP HISTORY LOG	Displays the last four fault codes for the drive. Refer to page 50 for further information.	-
11 REFERENCE SELECT			
The drive can accept a variety of references in addition to the conventional analog input, potentiometer and keypad signals.			
1103	PRIMARY COMMAND SOURCE MODE		0: Terminal Control
	0: TERMINAL CONTROL.	The drive responds directly to signals applied to the control terminals.	
	1: UNI-DIRECTIONAL KEYPAD CONTROL	The drive can be controlled in the forward direction only using an external or remote Keypad	
	2: BI-DIRECTIONAL KEYPAD CONTROL.	The drive can be controlled in the forward and reverse directions using an external or remote Keypad. Pressing the keypad START button toggles between forward and reverse.	
	3: MODBUS NETWORK CONTROL.	Control via Modbus RTU (RS485) using the internal accel / decel ramps	
	4 : MODBUS NETWORK CONTROL.	Control via Modbus RTU (RS485) interface with accel / decel ramps updated via Modbus	
	5 : PI CONTROL	User PI control with external feedback signal	
	6 : PI ANALOG SUMMATION CONTROL.	PI control with external feedback signal and summation with analog input 1	
12 CONSTANT SPEEDS			
Constant speeds. Constant speed activation overrides the external speed reference. Constant speed selections are ignored if the drive is in the local control mode.			
Refer to section 9.1 for how to make constant speed selections from the drive control terminals.			
Preset Speeds / Frequencies selected by digital inputs depending on the setting of Parameter 9902 DIGITAL INPUTS FUNCTION SELECT. If Parameter 9908 MOTOR RATED SPEED = 0, the values are entered as Hz. If Parameter 9908 > 0, the values are entered as Rpm. Setting a negative value will reverse the direction of motor rotation.			
1202	PRESET / JOG FREQUENCY / SPEED 1	Defines constant speed 1 (that is the drive output frequency)	5.0Hz/RPM
	2007...-2008	Output Frequency	
1203	PRESET / JOG FREQUENCY / SPEED 2	Defines constant speed 2 (that is the drive output frequency)	10.0Hz/RPM
	2007...-2008	Output Frequency	
1204	PRESET / JOG FREQUENCY / SPEED 3	Defines constant speed 3 (that is the drive output frequency)	25.0Hz/RPM
	2007...-2008	Output Frequency	



Parameters in the Short parameter mode			
No.	Name/Value	Description	Def
13 ANALOG INPUTS			
1301	ANALOG INPUT 1 OFFSET	Sets an offset, as a percentage of the full scale range of the input, which is applied to the analog input signal	0.0%
	-500...500 %	Value in percent of the full scale range of the input Example: If the analog input signal format is 0-10V, offset = 20% . An analog input signal level of 7 Volts gives the following result :- Analog input level (%) = 7/10 = 70% Result = 70-20 (%) = 50%	
20 LIMITS			
2008	MAXIMUM FREQUENCY / SPEED LIMIT	Maximum output frequency or motor speed limit – Hz or rpm. If parameter 9908 MOTOR RATED SPEED >0, the value entered / displayed is in Rpm	60.0 Hz
	2007 ...500.0 Hz	Maximum frequency	
21 START/STOP			
2102	STOP MODE	Selects the motor stop function	0 = Ramp to stop
	0 : RAMP TO STOP	When the enable signal is removed, the drive will ramp to stop, with the rate controlled by parameter 2203 DECEL RAMP TIME as described above. In this mode, the drive brake transistor is disabled	
	1 : COAST TO STOP	When the enable signal is removed, the drive output is immediately disabled, and the motor will coast (freewheel) to stop. If the load can continue to rotate due to inertia, and the drive may possibly be re-enabled whilst the motor is still rotating, the spin start function (Parameter 2101 SPIN START ENABLE) should be enabled. In this mode, the drive brake transistor is disabled.	
	2 : RAMP TO STOP	When the enable signal is removed, the drive will ramp to stop, with the rate controlled by Parameter 2203 DECEL RAMP TIME as described above. The ACS255 Brake chopper is also enabled in this mode.	
	3 : COAST TO STOP	When the enable signal is removed, the drive output is immediately disabled, and the motor will coast (freewheel) to stop. If the load can continue to rotate due to inertia, and the drive may possibly be re-enabled whilst the motor is still rotating, the spin start function (Parameter 2101 SPIN START ENABLE) should be enabled. The drive brake chopper is enabled in this mode, however it will only activate when required during a change in the drive frequency setpoint, and will not activate when stopping.	
22 ACCEL/DECEL			
2202	ACCELERATION RAMP TIME	Acceleration ramp time from 0 to base speed (Parameter 9907 MOTOR RATED FREQUENCY) in seconds.	5.0 s
	0.00...600.0 s	Time	
2203	DECELERATION RAMP TIME	Deceleration ramp time from base speed (Parameter 9907 MOTOR RATED FREQUENCY) to standstill in seconds. When set to zero, fastest possible ramp time without trip is activated.	5.0 s
	0.00...600.0 s	Time	



10.3. Read Only Status parameters

10.3.1. Read Only Status parameter access and navigation.

The user must be in the **Long Parameter group** to gain access to the Read only status parameters, See section 10.1.1 for how to navigate to the Long Parameter group.

In the Long Parameter Group when the user scrolls to parameter "0000", pressing  will display "0104", the User can then scroll to the required Read only status parameter (as listed in the table above). Pressing  once more will then display the value of that particular Read only status parameter.

For those parameters which have multiple values (e.g. software ID parameter **3301**), pressing the  and  keys will display the different values within that parameter.

Pressing  returns to the next level up. If  is then pressed again (without pressing  or ), the display changes to the next level up (main parameter level, i.e. Parameter "0000").

The following table includes the descriptions of all Read Only status parameters.

Actual signals		
No.	Name/Value	Description
01 OPERATING DATA		Basic signals for monitoring the drive (read-only). For selection of an actual signal to be displayed on the control panel, see parameter 3405 DISPLAY SCALING SOURCE.
0102	ROTOR SPEED (ESTIMATED)	In vector control mode, this parameter displays the estimated rotor speed of the motor.
0104	MOTOR CURRENT	8 most recent values prior to trip, updated every 255ms
0107	DC BUS VOLTAGE	Displays the instantaneous DC Bus Voltage internally within the drive in V DC. (0...1000V dc)
0109	APPLIED MOTOR VOLTAGE	Displays the instantaneous output voltage from the drive to the motor V AC. (0...600V AC)
0110	INTERNAL HEATSINK TEMPERATURE	Temperature of heatsink in °C (-20 ... 100 °C)
0111	SPEED REFERENCE INPUT	Displayed in Hz if Parameter 9908 MOTOR RATED SPEED = 0, otherwise displayed in RPM. (-2008 ... 2008)
0115	kWh/MWh METER	Total number of kWh/MWh consumed by the drive.
0120	ANALOG INPUT 1 APPLIED SIGNAL LEVEL	Displays the signal level applied to analog input 1 (Terminal 6) in % after scaling and offsets have been applied.
0121	ANALOG INPUT 2 APPLIED SIGNAL LEVEL	Displays the signal level applied to analog input 2 (Terminal 4) in % after scaling and offsets have been applied.
0126	PI CONTROLLER OUTPUT	Displays the output level of the PI Controller in %.
0140	HOURS RUN METER	Not affected by resetting factory default parameters. (0 to 99 999 hours)
0145	THERMISTOR TEMPERATURE LOG	8 most recent values prior to trip, updated every 500ms. (-20 ... 120 °C)
0160	DIGITAL INPUT STATUS	Binary value. Displays the status of the drive inputs, starting with the left hand side digit = Digital Input 1 etc.
0183	DC BUS VOLTAGE RIPPLE LEVEL	Displays the level of ripple present on the DC Bus Voltage in VDC. This parameter is used by the drive for various internal protection and monitoring functions.
0188	OPERATING TIME ACCUMULATED WITH HEATSINK TEMPERATURE ABOVE 85°C	Displays the amount of time in hours and minutes that the ACS255 has operated for during its lifetime with a heatsink temperature in excess of 85°C. This parameter is used by the ACS255 for various internal protection and monitoring functions. (HH:MM:SS)
0189	OPERATING TIME ACCUMULATED WITH AMBIENT TEMPERATURE ABOVE 80°C	Displays the amount of time in hours and minutes that the ACS255 has operated for during its lifetime with an ambient temperature in excess of 80°C. This parameter is used by the ACS255 for various internal protection and monitoring functions. (HH:MM:SS)
0190	DRIVE INTERNAL COOLING FAN TOTAL OPERATING TIME	Displays the total operating time of the ACS255 internal cooling fans. The first value shown is the number of hours. Pressing the Up key will display the minutes and seconds. This is used for scheduled maintenance information (HH:MM:SS)
0192	DC BUS VOLTAGE RIPPLE LOG (22ms) (V DC)	8 most recent values prior to trip, updated every 22ms.
0193	HEATSINK TEMPERATURE LOG (30s) (°C)	8 most recent values prior to trip, updated every 30s.
0194	AMBIENT TEMPERATURE LOG (30s) (°C)	8 most recent values prior to trip, updated every 30s.

04 FAULT HISTORY		Fault history (read-only)
0402	RUN TIME SINCE LAST TRIP (1)	Run-time clock stopped by drive disable (or trip), reset on next enable only if a trip occurred. Reset also on next enable after a drive power down. (0 to 99 999 hours)
0406	DC BUS VOLTAGE LOG	8 most recent values prior to trip, updated every 255ms. (0 ... 1000V)
0415	RUN TIME SINCE LAST TRIP (2)	Run-time clock stopped by drive disable (or trip), reset on next enable only if a trip occurred (under-volts not considered a trip) – not reset by power down / power up cycling unless a trip occurred prior to power down. (0 to 99 999 hours)
0416	RUN TIME SINCE LAST DISABLE	Run-time clock stopped on drive disable, value reset on next enable. (0 to 99 999 hours)
0417	DRIVE EFFECTIVE SWITCHING FREQUENCY	Actual drive effective output switching frequency. This value maybe lower than the selected frequency in parameter 2606 EFFECTIVE SWITCHING FREQUENCY if the drive is too hot. The drive will automatically reduce the switching frequency to prevent an over temperature trip and maintain operation. (4 to 32 kHz)
33 INFORMATION		Firmware package version, serial number etc..
3301	SOFTWARE ID, IO & MOTOR CTRL	e.g. "1.00", "47AE" Version number and checksum. "1" on LH side indicates I/O processor, "2" indicates motor control
3303	DRIVE SERIAL NUMBER	000000 ... 999999 00-000 ... 99-999 Unique drive serial number e.g. 540102 / 32 / 005
3304	DRIVE IDENTIFIER	Drive rating (Drive rating, drive type e.g. 0.37, 1 230,3P-out)

10.4. Parameters in the Long parameter mode

The following table includes the complete descriptions of all parameters that are visible only in the Long parameter mode. See page 31 for how to select the parameter mode.

Parameters in the Long parameter mode			
Index	Name/Selection	Description	Def
0000	Read only parameters access	Press the  button when in this parameter to access the read only parameters as listed on page 34.	-
04	FAULT HISTORY	Fault history (read-only)	
0401	TRIP HISTORY LOG	Displays the last four fault codes for the drive. Refer to page 50 for further information. Press UP or DOWN to step through all four. The most recent trip is always displayed first. The Under Voltage (F0006) trip is only stored once.	-
11	REFERENCE SELECT	The drive can accept a variety of references in addition to the conventional analog input, potentiometer and keypad signals.	
1100	KEYPAD MODE RESTART FUNCTION	This parameter is active only when operating in Keypad Control Mode (parameter 1103 PRIMARY COMMAND SOURCE MODE = 1 or 2).	1 : PREVIOUS SPEED, KEYPAD START
	0 MINIMUM SPEED, KEYPAD START	Keypad Start and Stop keys are active, and control terminals 1 and 2 must be linked together. The drive will always start at the Minimum Frequency / Speed (parameter 2007)	
	1 : PREVIOUS SPEED, KEYPAD START	Keypad Start and Stop keys are active, and control terminals 1 and 2 must be linked together. The drive will always start at the last operating Frequency / Speed	
	2 : MINIMUM SPEED, TERMINAL ENABLE	Allows the drive to be started from the control terminals directly, and the keypad Start and Stop keys are ignored. The drive will always start at the Minimum Frequency / Speed (parameter 2007)	
	3 : PREVIOUS SPEED, TERMINAL ENABLE	Allows the drive to be started from the control terminals directly, and the keypad Start and Stop keys are ignored. The drive will always start at the last operating Frequency / Speed.	
1103	PRIMARY COMMAND SOURCE MODE		0: Terminal Control
	0: TERMINAL CONTROL.	The drive responds directly to signals applied to the control terminals.	
	1: UNI-DIRECTIONAL KEYPAD CONTROL	The drive can be controlled in the forward direction only using an external or remote Keypad	
	2: BI-DIRECTIONAL KEYPAD CONTROL.	The drive can be controlled in the forward and reverse directions using an external or remote Keypad. Pressing the keypad START button toggles between forward and reverse.	
	3: MODBUS NETWORK CONTROL.	Control via Modbus RTU (RS485) using the internal accel / decel ramps	
	4 : MODBUS NETWORK CONTROL.	Control via Modbus RTU (RS485) interface with accel / decel ramps updated via Modbus	
	5 : PI CONTROL	User PI control with external feedback signal	
	6 : PI ANALOG SUMMATION CONTROL.	PI control with external feedback signal and summation with analog input 1	
12	CONSTANT SPEEDS	Constant speeds. Constant speed activation overrides the external speed reference. Constant speed selections are ignored if the drive is in the local control mode. Refer to section 9.1 for how to make constant speed selections from the drive control terminals. Preset Speeds / Frequencies selected by digital inputs depending on the setting of Parameter 9902 DIGITAL INPUTS FUNCTION SELECT. If Parameter 9908 MOTOR RATED SPEED = 0, the values are entered as Hz. If Parameter 9908 > 0, the values are entered as Rpm. Setting a negative value will reverse the direction of motor rotation.	
1202	PRESET / JOG FREQUENCY / SPEED 1 2007...-2008	Defines constant speed 1 (that is the drive output frequency) Output Frequency	0.0 Hz/RPM
1203	PRESET / JOG FREQUENCY / SPEED 2 2007...-2008	Defines constant speed 2 (that is the drive output frequency) Output Frequency	0.0 Hz/RPM
1204	PRESET / JOG FREQUENCY / SPEED 3 2007...-2008	Defines constant speed 3 (that is the drive output frequency) Output Frequency	0.0 Hz/RPM
1205	PRESET / JOG FREQUENCY / SPEED 4 2007...-2008	Defines constant speed 4 (that is the drive output frequency) Output Frequency	0.0 Hz/RPM

Parameters in the Long parameter mode			
Index	Name/Selection	Description	Def
13	ANALOG INPUTS		
1300	ANALOG INPUT 1 SIGNAL FORMAT	Selects the type of reference source into terminal 6.	U 0- 10
	U 0- 10	0 to 10 Volt Signal(Uni-polar).The drive will remain at 0.0Hz if the analog reference after scaling and offset are applied is <0.0%.	
	b- 10- 10	0 to 10 Volt Signal (Bi-polar). The drive will operate the motor in the reverse direction of rotation if the analog reference after scaling and offset are applied is <0.0%	
	A 0-20	0 to 20mA Signal	
	t 4-20	4 to 20mA Signal, the ACS255 will trip and show the fault code F0007 if the signal level falls below 3mA	
	r 4-20	4 to 20mA Signal, the ACS255 will ramp to stop if the signal level falls below 3mA	
	t 20-4	20 to 4mA Signal, the ACS255 will trip and show the fault code F0007 if the signal level falls below 3mA	
	r 20-4	20 to 4mA Signal, the ACS255 will ramp to stop if the signal level falls below 3mA	
	I n Pot	Integrated potentiometer	
1301	ANALOG INPUT 1 OFFSET	Sets an offset, as a percentage of the full scale range of the input, which is applied to the analog input signal	0.0%
	-500...500 %	Value in percent of the full scale range of the input Example: If the analog input signal format is 0-10V, offset = 20% . An analog input signal level of 7 Volts gives the following result :- Analog input level (%) = 7/10 = 70% Result = 70-20 (%) = 50%	
1302	ANALOG INPUT 1 SCALING	Scales the analog input by this factor, (as a percentage of the full scale range of this input).	100.0
	0.0...2000.0 %	Example: If parameter 1300 ANALOG INPUT 1 FORMAT is set for 0 – 10V, and the scaling factor is set to 200.0%, a 5 volt input will result in the drive running at maximum speed as set in parameter 2008 MAX SPEED LIMIT	
1304	ANALOG INPUT 2 SIGNAL FORMAT	Selects the type of reference source into terminal 4.	U 0- 10
	U 0- 10	0 to 10 Volt Signal	
	A 0-20	0 to 20mA Signal	
	t 4-20	4 to 20mA Signal, the ACS255 will trip and show the fault code F0007 if the signal level falls below 3mA	
	r 4-20	4 to 20mA Signal, the ACS255 will ramp to stop if the signal level falls below 3mA	
	t 20-4	20 to 4mA Signal, the ACS255 will trip and show the fault code F0007 if the signal level falls below 3mA	
	r 20-4	20 to 4mA Signal, the ACS255 will ramp to stop if the signal level falls below 3mA	
14	RELAY OUTPUTS	Status information indicated through relay output and relay operating delays	
1401	OUTPUT RELAY FUNCTION SELECT	Selects the function assigned to the relay output. The relay has two output terminals, Logic 1 indicates the relay is active, and therefore terminals 10 and 11 will be linked together.	1 : Drive READY
	0 : DRIVE ENABLED (RUNNING)	Logic 1 when the motor is enabled	
	1 : DRIVE READY	Logic 1 when power is applied to the drive and no fault exists	
	2 : AT TARGET FREQUENCY (SPEED)	Logic 1 when the output frequency matches the setpoint frequency	
	3: DRIVE TRIPPED	Logic 1 when the drive is in a fault condition	
	4 : OUTPUT FREQUENCY >= LIMIT	Logic 1 when the output frequency exceeds the adjustable limit set in 3200 RELAY THRESHOLD LEVEL	
	5 : OUTPUT CURRENT >= LIMIT	Logic 1 when the motor current exceeds the adjustable limit set in 3200 RELAY THRESHOLD LEVEL	
	6 : OUTPUT FREQUENCY < LIMIT	Logic 1 when the output frequency is below the adjustable limit set in 3200 RELAY THRESHOLD LEVEL	
	7 : OUTPUT CURRENT < LIMIT	Logic 1 when the motor current is below the adjustable limit set in 3200 RELAY THRESHOLD LEVEL	

Parameters in the Long parameter mode			
Index	Name/Selection	Description	Def
15	ANALOG/DIGITAL OUTPUTS	Analog output signal processing	
1501	ANALOG OUTPUT FUNCTION SELECT	Selects the type of output signal information indicated from terminal 8. Note : When using settings 0 – 7 the output is a digital format (Logic 1 = 24V). When using settings 8-9 the output is an analog format.	8 : OUTPUT FREQUENCY (MOTOR SPEED).
	0 : DRIVE ENABLED (RUNNING).	Logic 1 when the ACS255 is enabled (Running)	
	1 : DRIVE READY.	Logic 1 When no Fault condition exists on the drive	
	2 : AT TARGET FREQUENCY (SPEED).	Logic 1 when the output frequency matches the setpoint frequency	
	3: DRIVE TRIPPED.	Logic 1 when the drive is in a fault condition	
	4 : OUTPUT FREQUENCY >= LIMIT	Logic 1 when the output frequency exceeds the adjustable limit set in parameter 3200 RELAY THRESHOLD LEVEL	
	5 : OUTPUT CURRENT >= LIMIT	Logic 1 when the motor current exceeds the adjustable limit set in parameter 3200 RELAY THRESHOLD LEVEL	
	6 : OUTPUT FREQUENCY < LIMIT	Logic 1 when the output frequency is below the adjustable limit set in parameter 3200 RELAY THRESHOLD LEVEL	
	7 : OUTPUT CURRENT < LIMIT.	Logic 1 when the motor current is below the adjustable limit set in parameter 3200 RELAY THRESHOLD LEVEL	
	8 : OUTPUT FREQUENCY (MOTOR SPEED).	0 to parameter 2008 MAXIMUM FREQUENCY / SPEED LIMIT	
	9 : OUTPUT (MOTOR) CURRENT.	0 to 200% of parameter 9906 MOTOR RATED CURRENT	
16	SYSTEM CONTROLS	Parameter lock etc.	
1602	PARAMETER ACCESS UNLOCK	If Parameter 1603 has had a value entered, then the matching value needs to be entered here in order to give read-write access to the parameters.	0
	0...65535	See page 42 for more details	
1603	PARAMETER ACCESS CODE DEFINITION	To make all parameters Read only, enter a value in this parameter.	0
	0...65535	See page 42 for more details	
20 LIMITS		Drive operation limits	
2007	MINIMUM FREQUENCY / SPEED LIMIT	Minimum output frequency or motor speed limit – Hz or rpm. If parameter 9908 MOTOR RATED SPEED >0, the value entered / displayed is in Rpm	0.0 Hz
	0.0 HZ... 2008	Minimum frequency	
2008	MAXIMUM FREQUENCY / SPEED LIMIT	Maximum output frequency or motor speed limit – Hz or rpm. If parameter 9908 MOTOR RATED SPEED >0, the value entered / displayed is in Rpm	60.0 Hz
	2007...500.0 Hz	Maximum frequency	
2020	BRAKE CHOPPER ENABLE		0 : DISABLED
	0 : DISABLED		
	1 : ENABLED WITH SOFTWARE PROTECTION.	Enables the internal brake chopper with software protection for a 200W continuous rated resistor	
	2 : ENABLED WITHOUT SOFTWARE PROTECTION.	Enables the internal brake chopper without software protection. An external thermal protection device should be fitted.	
21 START/STOP		Start and Stop modes of the motor	
2101	FLYING START (Size E2 & E3 ONLY) / DC INJECTION TIME ON START (Size E1 ONLY)	Starting the drive connected to a rotating motor.	0 : Disabled
	0 : DISABLED		
	1 : ENABLED.	When enabled, on start up the drive will attempt to determine if the motor is already rotating, and will begin to control the motor from its current speed. A short delay may be observed when starting motors which are not turning/On Size E1 only this parameter Sets a time for which DC current is injected into the motor to ensure it is stopped when the drive is enabled.	

Parameters in the Long parameter mode			
Index	Name/Selection	Description	Def
2102	STOP MODE	Selects the motor stop function	0 : RAMP TO STOP
	0 : RAMP TO STOP	When the enable signal is removed, the drive will ramp to stop, with the rate controlled by parameter 2203 DECEL RAMP TIME as described above. If the mains supply is lost, the drive will try to continue running by reducing the speed of the load, and using the load as a generator.	
	1 : COAST TO STOP	When the enable signal is removed, or if the mains supply is lost, the motor will coast (freewheel) to stop	
	2 : RAMP TO STOP	When the enable signal is removed, the drive will ramp to stop, with the rate controlled by parameter 2203 DECELERATION RAMP TIME. If the mains supply is lost the drive will ramp to stop using parameter 2206 2nd DECELERATION RAMP TIME (FAST STOP) (decel ramp with dynamic brake control).	
	3 : COAST TO STOP	When the enable signal is removed, the drive output is immediately disabled, and the motor will coast (freewheel) to stop. If the load can continue to rotate due to inertia, and the drive may possibly be re-enabled while the motor is still rotating, the spin start function (Parameter 2101 SPIN START ENABLE) should be enabled. The drive brake chopper is enabled in this mode, however it will only activate when required during a change in the drive frequency setpoint, and will not activate when stopping.	
2104	DC INJECTION TIME ON STOP	Defines the time for which a DC current is injected into the motor once the output frequency reaches 0.0Hz. The voltage level is the same as the boost level set in parameter 2603.	0.0
	0.0...25.0 s		
2108	TERMINAL MODE RESTART FUNCTION	Defines the behavior of the drive relating to the enable digital input and also configures the Automatic Restart function.	Auto-0
	EDGE-r	Following Power on or reset, the drive will not start if Digital Input 1 remains closed. The Input must be closed after a power on or reset to start the drive.	
	Auto-0	Following a Power On or Reset, the drive will automatically start if Digital Input 1 is closed.	
	Auto-1 to Auto-5	Following a trip, the drive will make up to 5 attempts to restart at 20 second intervals. The drive must be powered down to reset the counter. The numbers of restart attempts are counted, and if the drive fails to start on the final attempt, the drive will fault and will require the user to manually reset the fault.	
22 ACCEL/DECEL		Acceleration and deceleration times	
2202	ACCELERATION RAMP TIME	Acceleration ramp time from 0 to base speed (Parameter 9907 MOTOR RATED FREQUENCY) in seconds.	5.0 s
	0.00...600.0 s	Time	
2203	DECELERATION RAMP TIME	Deceleration ramp time from base frequency (Parameter 9907 MOTOR RATED FREQUENCY) to standstill in seconds. When set to zero, fastest possible ramp time without trip is activated. When set to 0.00, the value of 2206 is used.	5.0 s
	0.00...600.0 s	Time	
2206	2nd DECELERATION RAMP TIME (FAST STOP)	This parameter allows an alternative deceleration ramp down time to be programmed into the ACS255, which can be selected by digital inputs (dependent on the setting of Parameter 9902 DIGITAL INPUTS FUNCTION SELECT or selected automatically in the case of a mains power loss if parameter 2102 STOP MODE = 2.	0.00
	0.00...25.0 s	When set to 0.00, the drive will coast to stop.	
25 CRITICAL SPEEDS		Speed bands with which the drive is not allowed to operate. The Skip Frequency function is used to avoid the ACS255 operating at a certain output frequency, for example at a frequency which causes mechanical resonance in a particular machine.	
2500	SKIP FREQUENCY HYSTERESIS BAND	The drive output frequency will ramp through the defined band at the rates set in parameter 2202 and 2203 respectively, and will not hold any output frequency within the defined band. If the frequency reference applied to the drive is within the band, the drive output frequency will remain at the upper or lower limit of the band.	0.0 Hz/Rpm
	0.0...2008		
2501	SKIP FREQUENCY	Defines the center point of the skip frequency band, and is used conjunction with parameter 2550 SKIP FREQUENCY HYSTERESIS BAND	
	0.0...2008		
26 MOTOR CONTROL		Motor control variables	
2601	ENERGY OPTIMIZER	Enables or disables Energy optimizer	0 : Disabled
	0 : DISABLED		
	1 : ENABLED	The Energy Optimizer attempts to reduce the overall energy consumed by the drive and motor when operating at constant speeds and light loads. The output voltage applied to the motor is reduced. The Energy Optimizer is intended for applications where the drive may operate for some periods of time with constant speed and light motor load, whether constant or variable torque.	

Parameters in the Long parameter mode			
Index	Name/Selection	Description	Def
2603	V/F MODE VOLTAGE BOOST	Voltage boost is used to increase the applied motor voltage at low output frequencies, in order to improve low speed and starting torque. Excessive voltage boost levels may result in increased motor current and temperature, and force ventilation of the motor may be required. A suitable setting can usually be found by operating the motor under low load or no load conditions at approximately 5Hz, and adjusting parameter 2603 until the motor current is no more than 80% of the rated full load current.	3.0 %
	0.0...20.0 %		
2606	EFFECTIVE SWITCHING FREQUENCY	Sets maximum effective switching frequency of the drive. If "rEd" is displayed, the switching frequency has been reduced to the level in Parameter 0417 INTERNAL EFFECTIVE SWITCHING FREQUENCY due to excessive drive heat sink temperature. Refer to parameter 0417 INTERNAL EFFECTIVE SWITCHING FREQUENCY for further information regarding operation at higher switching frequency.	Drive Rating Dependent
	4...32 kHz		
2610	V/F CHARACTERISTIC ADJUSTMENT VOLTAGE	Used in conjunction with parameter 2611 V/F CHARACTERISTIC ADJUSTMENT FREQUENCY	0 V
	0 V...255/500		
2611	V/F CHARACTERISTIC ADJUSTMENT FREQUENCY	This parameter in conjunction with parameter 2610 V/F CHARACTERISTIC ADJUSTMENT VOLTAGE sets a frequency point at which the voltage set in parameter 2611 V/F CHARACTERISTIC ADJUSTMENT FREQUENCY is applied to the motor. Care must be taken to avoid overheating and damaging the motor when using this feature. See section 10.5 for further information.	0.0 Hz
	0.0 Hz...Value set in 9907		
30 FAULT FUNCTIONS		Programmable protection functions	
3005	THERMAL OVERLOAD VALUE RETENTION		1 : ENABLED
	0 : DISABLED	Alternative means of protecting the motor from thermal overload must be applied (e.g. PTC thermistor)	
	1 : ENABLED	The drive will retain the motor thermal overload value following a mains power cycle.	
32 SUPERVISION		Signal supervision. The drive monitors whether certain user selectable variables are within the user-defined limits. The user may set limits for speed, current etc. Supervision status can be monitored with relay output. See parameter group 14 RELAY OUTPUTS.	
3200	RELAY THRESHOLD LEVEL	Adjustable threshold level used in conjunction with settings 4 to 7 of parameter 1401 OUTPUT RELAY FUNCTION SELECT	100.0 %
	0.0...200.0 %		
34 PANEL DISPLAY		Selection of actual signals to be displayed on the drives front panel e.g. to display conveyer speed in feet per second based on the output frequency	
3400	DISPLAY SPEED SCALING FACTOR	Allow the user to display an alternative output unit scaled from an existing parameter,. This function is disabled if set to 0.000.	0.000
	0.000...6.000		
40 PROCESS PI SETUP		Process PI control parameter set	
4001	PI PROPORTIONAL GAIN	PI Controller Proportional Gain. Higher values provide a greater change in the drive output frequency in response to small changes in the feedback signal. Too high a value can cause instability	1.0
	0.0...30.0		
4002	PI INTEGRAL TIME CONSTANT	PI Controller Integral Time. Larger values provide a more damped response for systems where the overall process responds slowly	1.0 s
	0.0...30.0 S		
4005	PI OPERATING MODE		0
	0 : DIRECT OPERATION	Use this mode if an increase in the motor speed should result in an increase in the feedback signal	
	1 : INVERSE OPERATION	Use this mode if an increase in the motor speed should result in a decrease in the feedback signal	
4010	PI REFERENCE (SETPOINT) SOURCE SELECT	Selects the source for the PID Reference / Setpoint	0
	0	Digital Preset Setpoint. Parameter 4011 PI Digital Reference (Setpoint) is used	
	1	Analog Input 1 Setpoint	
4011	PI DIGITAL REFERENCE (SETPOINT)	When parameter 4010 PID REFERENCE (SETPOINT) SOURCE SELECT = 0, this parameter sets the preset digital reference (setpoint) used for the PID Controller	0 %
	0.0...100.0 %		
4016	PI FEEDBACK SIGNAL SOURCE SELECT		0
	0	Analog Input 2(Terminal 4)	
	1	Analog Input 1(Terminal 6)	
	2	Motor Current	

Parameters in the Long parameter mode			
Index	Name/Selection	Description	Def
53 COMMUNICATIONS PARAMETERS			
5302	SERIAL COMMUNICATIONS CONFIGURATION	This parameter has three sub settings used to configure the Modbus RTU Serial Communications. The Sub Parameters are : Drive Address : Adr 0 to Adr 63 Baud Rate : 9.6kbps to 115.2kbps Watchdog Timeout : 0 (Disabled, 300, 3000 milliseconds)	1
99 START-UP DATA			
Application macros. Definition of motor set-up data. As shown in the table below Parameter 9902 has a number of pre-programmed parameter sets (and terminal functions) which the user selects to best suit the application.			
9902	DIGITAL INPUTS FUNCTION SELECT	Defines the function of the digital inputs depending on the control mode setting in Parameter 1103 PRIMARY COMMAND SOURCE MODE. See Application macros on page 28.	1
9905	MOTOR RATED VOLTAGE	This parameter should be set to the rated (nameplate) voltage of the motor (Volts).	Drive Rating Dependent
	110V/230V rated drives 0...255V 400V rated drives 0...500V	Voltage Note : The stress on the motor insulation is always dependent on the drive supply voltage. This also applies in the case where the motor voltage rating is lower than the rating of the drive and the supply of the drive.	
9906	MOTOR RATED CURRENT	This parameter should be set to the rated (nameplate) current of the motor.	Drive Rating Dependent
	0.2*drive rated output current...1.0*drive rated output current	Current	
9907	MOTOR RATED FREQUENCY	This parameter should be set to the rated (nameplate) frequency of the motor	60Hz
	25...500Hz	Frequency	
9908	MOTOR RATED SPEED	This parameter can optionally be set to the rated (nameplate) rpm of the motor. When set to the default value of zero, all speed related parameters are displayed in Hz, and the slip compensation for the motor is disabled. Entering the value from the motor nameplate enables the slip compensation function, and the ACS255 display will now show motor speed in estimated rpm. All speed related parameters, such as Minimum and Maximum Speed, Preset Speeds etc. will also be displayed in Rpm.	0 Rpm
	0...30000 Rpm		

10.5. Adjusting the Voltage / Frequency (V/f) characteristics

	<p>The V/f characteristic is defined by several parameters as follows :- Parameter 9905 : Motor Rated Voltage Parameter 9907 : Motor Rated Frequency</p> <p>The voltage set in parameter 9905 is applied to the motor at the frequency set Under normal operating conditions, the voltage is linearly reduced at any point below the motor rated frequency to maintain a constant motor torque output as shown by the line 'A' on the graph.</p> <p>By using parameters parameter 2610 and 2611, the voltage to be applied at a particular frequency can be directly set by the user, thereby altering the V/F characteristic. Reducing the voltage at a particular frequency reduces the current in the motor and hence the torque and power, hence this function can be used in fan and pump applications where a variable torque output is desired by setting the parameters as follows :- Parameter 2610 = $9905 / 4$ Parameter 2611 = $9907 / 2$</p> <p>This function can also be useful if motor instability is experienced at certain frequencies, if this is the case increase or decrease the voltage (Parameter 2610) at the speed of instability (Parameter 2611).</p> <p>For applications requiring energy saving, typically HVAC and pumping, the energy optimizer (Parameter 2601) parameter can be enabled. This automatically reduces the applied motor voltage on light load.</p>
--	--

10.6. Motor Thermistor Connection

	1 : + 24 Volt 4 : External Trip	The motor thermistor should be connected between terminals 1 and 4 as shown. A setting of Parameter 9902 where Digital Input 3 is programmed for 'External Trip' must be used. The current flow through the thermistor is automatically controlled to prevent a failure.
--	------------------------------------	---

10.7. Parameters in the Advanced parameter mode

The following table describes the parameters that are visible in the Advanced parameter mode. See page 25 for how to select the parameter mode. Advanced parameters are not included in the Long parameter mode.

Parameters in the Advanced parameter mode																								
Index	Name/Selection	Description	Def																					
2017	Maximum Current Limit	Defines the max current limit in vector control modes.	150 %																					
	0.0...175.00																							
2105	DC Injection Speed	Sets the speed at which DC injection current is applied during braking to Stop, allowing DC to be injected before the drive reaches zero speed if desired.	0.0 Hz/Rpm																					
	0.0... 2008																							
2106	DC Injection Current	Sets the level of DC injection braking current applied according to the conditions set in 2104 and 2105 .	20 %																					
	0.0...100.0																							
2301	Vector Mode Gain	Single Parameter for Vector speed loop tuning. Affects P & I terms simultaneously. Not active when 9903 = 1.	50 %																					
	0.0...200.0																							
2605	Operating Mode Select	Provides a quick set up to configure key parameters according to the intended application of the drive. Parameters are preset according to the table.	0																					
		<table border="1"> <thead> <tr> <th>Setting</th> <th>Application</th> <th>Current Limit (2017)</th> <th>Torque Characteristic (2610 & 2611)</th> <th>Spin Start (2101)</th> </tr> </thead> <tbody> <tr> <td>0</td> <td>General</td> <td>150%</td> <td>Constant</td> <td>0 : Off</td> </tr> <tr> <td>1</td> <td>Pump</td> <td>110%</td> <td>Variable</td> <td>0 : Off</td> </tr> <tr> <td>2</td> <td>Fan</td> <td>110%</td> <td>Variable</td> <td>2 : On</td> </tr> </tbody> </table>	Setting	Application	Current Limit (2017)	Torque Characteristic (2610 & 2611)	Spin Start (2101)	0	General	150%	Constant	0 : Off	1	Pump	110%	Variable	0 : Off	2	Fan	110%	Variable	2 : On		
Setting	Application	Current Limit (2017)	Torque Characteristic (2610 & 2611)	Spin Start (2101)																				
0	General	150%	Constant	0 : Off																				
1	Pump	110%	Variable	0 : Off																				
2	Fan	110%	Variable	2 : On																				
	0: Industrial Mode	Intended for general purpose applications.																						
	1: Pump Mode	Intended for centrifugal pump applications.																						
	2: Fan Mode	Intended for Fan applications.																						
9903	Motor Control Mode	Selects the motor control method.	1																					
	0: Vector speed control mode																							
	1: V/f mode																							
	2: PM motor vector speed control																							
	3: Reserved																							
9910	Motor parameter Autotune	Drive measures the motor parameters for optimum control and efficiency. Following completion of the autotune.	0: Disable																					
	0: Disable																							
	1: Enable	Drive immediately carries out a non-rotating autotune, parameter 9910 MOTOR PARAMETER AUTO-TUNE ENABLE returns to 0 when completed.																						
11201	MOTOR STATOR RESISTANCE (Rs)	Motor stator resistance value measured during the autotune.	-																					
11203	MOTOR STATOR INDUCTANCE (Lsd)	For induction motors: phase stator inductance value.	-																					
11206	MOTOR STATOR q-axis INDUCTANCE (Lsq)	measured during the autotune	-																					

10.8. Preventing un-authorized parameter editing.

This function can be used to prevent an un-authorized person from changing the drive parameter values; this function is disabled when delivered from the factory.

Relevant Parameters

1602	Parameter Access Unlock
	0...65535
1603	Parameter Access code
	0...65535

Locking Parameter Access

- Go to Parameter **1603** (Long Parameter group) and enter in your chosen parameter access code.
- Press the  button to exit and parameter **1603** will then be hidden and all parameters will be "Read only" (except for Parameter **1602** which will remain "Read Write").

Unlocking Parameter Access

- Enter into Parameter **1602** the same value as **1603** (as chosen in "Locking Parameter Access" above).
- All parameters will now be "Read Write" and parameter **1603** will become visible and show the value which was originally programmed as the parameter access code.
- To disable this feature set parameter **1603** PARAMETER ACCESS CODE to zero and then **1602** PARAMETER ACCESS UNLOCK to zero.

11. Modbus RTU Communications

11.1. Introduction

The ACS255 can be connected to a Modbus RTU network via the RJ45 connector on the front of the drive.

11.2. Modbus RTU Specification

Protocol	Modbus RTU
Error check	CRC
Baud rate	9600bps, 19200bps, 38400bps, 57600bps, 115200bps (default)
Data format	1 start bit, 8 data bits, 1 stop bits, no parity.
Physical signal	RS 485 (2-wire)
User interface	RJ45 (see page 24 for more information)

11.3. RJ45 Connector Configuration

Connection details are shown on page 24.

11.4. Modbus Telegram Structure

The ACS255 supports Master / Slave Modbus RTU communications, using the 03 Read Holding Registers and 06 Write Single Holding Register commands. Many Master devices treat the first Register address as Register 0; therefore it may be necessary to convert the Register Numbers detail in section 45 by subtracting 1 to obtain the correct Register address. The telegram structure is as follows:-

Command 03 – Read Holding Registers					
Master Telegram	Length		Slave Response	Length	
Slave Address	1	Byte	Slave Address	1	Byte
Function Code (03)	1	Byte	Starting Address	1	Byte
1 st Register Address	2	Bytes	1 st Register Value	2	Bytes
No. Of Registers	2	Bytes	2 nd Register Value	2	Bytes
CRC Checksum	2	Bytes	Etc...		
			CRC Checksum	2	Bytes

Command 06 – Write Single Holding Register					
Master Telegram	Length		Slave Response	Length	
Slave Address	1	Byte	Slave Address	1	Byte
Function Code (06)	1	Byte	Function Code (06)	1	Byte
Register Address	2	Bytes	Register Address	2	Bytes
Value	2	Bytes	Register Value	2	Bytes
CRC Checksum	2	Bytes	CRC Checksum	2	Bytes

11.5. Modbus Register Map

Register Number	Par.	Type	Supported Commands	Function		Range	Explanation
				Low Byte	High Byte		
1	-	R/W	03,06	Drive Control Command		0..3	16 Bit Word. Bit 0 : Low = Stop, High = Run Enable Bit 1 : Low = Decel Ramp 1 (parameter 2203), High = Decel Ramp 2 (Parameter 2206) Bit 2 : Low = No Function, High = Fault Reset Bit 3 : Low – No Function, High = Coast Stop request
2	-	R/W	03,06	Modbus Speed reference setpoint		0..5000	Setpoint frequency x10, e.g. 100 = 10.0Hz
4	-	R/W	03,06	Acceleration and Deceleration Time		0..60000	Ramp time in seconds x 100, e.g. 255 = 2.5 seconds
6	-	R	03	Error code	Drive status		Low Byte = Drive Error Code, see page 50 High Byte = Drive Status as follows :- 0 : Drive Stopped, 1: Drive Running, 2: Drive Tripped
7		R	03	Output Motor Frequency		0..20000	Output frequency in Hz x10, e.g. 100 = 10.0Hz
8		R	03	Output Motor Current		0..480	Output Motor Current in Amps x10, e.g. 10 = 1.0 Amps
11	-	R	03	Digital input status		0..15	Indicates the status of the 4 digital inputs Lowest Bit = 1 Input 1
20	0120	R	03	Analog Input 1 value		0..1000	Analog input % of full scale x10, e.g. 1000 = 100%
21	0121	R	03	Analog Input 2 value		0..1000	Analog input % of full scale x10, e.g. 1000 = 100%
22	0111	R	03	Speed Reference Value		0..1000	Displays the setpoint frequency x10, e.g. 100 = 10.0Hz
23	0107	R	03	DC bus voltage		0..1000	DC Bus Voltage in Volts
24	0110	R	03	Drive temperature		0..100	Drive heatsink temperature in °C

All user configurable parameters are accessible as Holding Registers, and can be Read from or Written to using the appropriate Modbus command. To access drive parameters refer to section 11.6 for parameter register map.

Depending on the operating mode of the drive – some parameters cannot be changed whilst the drive is enabled for example. Modbus RTU supports sixteen bit integer values, hence where a decimal point is used in the drive parameter; the register value will be multiplied by a factor of ten, E.g. Read Value of parameter 2008 MAXIMUM FREQUENCY / SPEED LIMIT = 500, therefore this is 50.0Hz

11.6. Modbus Parameter Register Map

Register No	Parameter No	Description
129	0401	TRIP HISTORY LOG
130	1100	KEYPAD MODE RESTART FUNCTION
131	1103	PRIMARY COMMAND SOURCE MODE
132	1202	PRESET / JOG FREQUENCY / SPEED 1
133	1203	PRESET / JOG FREQUENCY / SPEED 2
134	1204	PRESET / JOG FREQUENCY / SPEED 3
135	1205	PRESET / JOG FREQUENCY / SPEED 4
136	1300	ANALOG INPUT 1 SIGNAL FORMAT
137	1301	ANALOG INPUT 1 OFFSET
138	1302	ANALOG INPUT 1 SCALING
139	1304	ANALOG INPUT 2 SIGNAL FORMAT
140	1401	OUTPUT RELAY FUNCTION SELECT
141	1501	ANALOG OUTPUT FUNCTION SELECT
142	1602	PARAMETER ACCESS UNLOCK
143	1603	PARAMETER ACCESS CODE DEFINITION
144	2007	MINIMUM FREQUENCY / SPEED LIMIT
145	2008	MAXIMUM FREQUENCY / SPEED LIMIT
146	2020	BRAKE CHOPPER ENABLE
147	2101	SPIN START (Size E2 & E3 ONLY) / DC INJECTION TIME ON START (Size E1 ONLY)
148	2102	STOP MODE
149	2104	DC INJECTION TIME ON STOP
150	2108	TERMINAL MODE RESTART FUNCTION
151	2202	ACCELERATION RAMP TIME
152	2203	DECELERATION RAMP TIME
153	2206	2nd DECELERATION RAMP TIME (FAST STOP)
154	2550	SKIP FREQUENCY HYSTERESIS BAND
155	2551	SKIP FREQUENCY
156	2601	ENERGY OPTIMISER
157	2603	V/F MODE VOLTAGE BOOST
158	2606	EFFECTIVE SWITCHING FREQUENCY
159	2610	V/F CHARACTERISTIC ADJUSTMENT VOLTAGE
160	2611	V/F CHARACTERISTIC ADJUSTMENT FREQUENCY
161	3005	THERMAL OVERLOAD VALUE RETENTION
162	3200	RELAY THRESHOLD LEVEL
163	3400	DISPLAY SPEED SCALING FACTOR
164	4001	PI PROPORTIONAL GAIN
165	4002	PI INTEGRAL TIME CONSTANT
166	4005	PI Operating Mode
167	4010	PI Reference (Setpoint) Source Select
168	4011	PI Digital Reference (Setpoint)
169	4016	PI Feedback Signal Source Select
170	5302	SERIAL COMMUNICATIONS CONFIGURATION
171	9902	DIGITAL INPUTS FUNCTION SELECT
172	9905	Motor Rated Voltage
173	9906	Motor Rated Current
174	9907	Motor Rated Frequency
175	9908	MOTOR RATED SPEED

12. Technical Data

12.1. Environmental

Operational ambient temperature range	(IP20) Open Drives :	-10 ... 50°C (frost and condensation free)
	(IP66) Enclosed Drives:	-10 ... 40°C (frost and condensation free)
Storage ambient temperature range	:	-40 ... 60°C
Maximum altitude	:	2000m. Derate above 1000m : 1% / 100m
Maximum humidity	:	95%, non-condensing

NOTE

For UL compliance: the average ambient temperature over a 24 hour period for 200-240V, 3HP (IP20) drives is 45°C. Also Refer to section 12.5 for Output current Derating Information.

12.2. Rating Tables

The following tables provide the output current rating information for the various ACS255 models. ABB Drives always recommend that selection of the correct ACS255 is based upon the motor full load *current* at the incoming supply voltage.

Cable sizes shown are the maximum possible that may be connected to the drive. Cables should be selected according to local wiring codes or regulations at the point of installation

The rated fuse currents given in the table are the maximums for the mentioned fuse types. If smaller fuse ratings are used, check that the fuse rms current rating is larger than the nominal input current. If 150% output power is needed, multiply nominal input current by 1.5.

Check that the operating time of the fuse is below 0.5 seconds. The operating time depends on the fuse type, the supply network impedance as well as the cross-sectional area, material and length of the supply cable. In case the 0.5 seconds operating time is exceeded with the gG or T fuses, ultra rapid (aR) fuses in most cases reduce the operating time to an acceptable level.

Note: Larger fuses must not be used when the input power cable is selected according to this table.

Model Number	Power (HP)	Nominal Input Current (A)	Nominal Input Current with 3% Line Choke (A)	Fuse (A)		Maximum Cable Size		Nominal Output Current (A)	Maximum Motor Cable Length	Recommended Brake Resistance (Ω)	Frame Size
				gG	UL Class CC or J	mm ²	AWG		Mtrs		
1-phase 110V...115V AC (+/-10%) - 3 Phase 230V Output											
ACS255-01U-02A3-1	0.5	7.8	7.1	10	10	8	8	2.3	100	N/A	E1
ACS255-01U-04A3-1	1	15.8	15.0	25	20	8	8	4.3	100	N/A	E1
ACS255-01U-05A8-1	1.5	21.9	20.1	32	30	8	8	5.8	100	50	E2
1-phase 200...240V AC (+/-10%) - 3 Phase Output											
ACS255-01U-02A3-2	0.5	3.7	2.9	10	6	8	8	2.3	100	N/A	E1
ACS255-01U-04A3-2	1.0	7.5	6.6	10	10	8	8	4.3	100	N/A	E1
ACS255-01U-06A1-2	1.5	11.0	9.7	16	15	8	8	6.1	100	N/A	E1
ACS255-01U-07A0-2	2.0	12.9	11.4	16	17.5	8	8	7	100	*100	E2
ACS255-01U-10A5-2	3.0	19.2	17.0	25	25	8	8	10.5	100	50	E2
ACS255-01U-15A3-2	5.0	29.2	25.9	40	40	8	8	15.3	100	50	E3
3-phase 200...240V AC (+/-10%) - 3 Phase Output											
ACS255-03U-02A3-2	0.5	3.4	2.8	6	6	8	8	2.3	100	N/A	E1
ACS255-03U-04A3-2	1.0	5.6	4.4	10	10	8	8	4.3	100	N/A	E1
ACS255-03U-06A1-2	1.5	8.1	6.3	10	15	8	8	6.1	100	N/A	E1
ACS255-03U-07A0-2	2.0	8.9	7.0	16	15	8	8	7	100	100	E2
ACS255-03U-10A5-2	3.0	12.1	9.9	16	17.5	8	8	10.5	100	50	E2
ACS255-03U-18A0-2	5.0	20.9	17.4	32	30	8	8	18	100	50	E3
ACS255-03U-24A0-2	7.5	26.4	22.0	40	35	8	8	24	100	22	E3
ACS255-03U-30A0-2	10.0	33.3	24.8	40	45	16	5	30	100	22	E4
ACS255-03U-46A0-2	15.0	50.1	40.0	63	70	16	5	46	100	22	E4
3-phase 380...480V AC (+/-10%) - 3 Phase Output											
ACS255-03U-01A2-4	0.5	1.9	1.5	6	6	8	8	1.2	100	N/A	E1
ACS255-03U-02A2-4	1	3.5	2.7	6	6	8	8	2.2	100	N/A	E1
ACS255-03U-03A3-4	1.5	4.6	3.3	10	10	8	8	3.3	100	N/A	E1
ACS255-03U-04A1-4	2	5.6	4.5	10	10	8	8	4.1	100	*200	E2
ACS255-03U-05A8-4	3	7.5	5.5	16	10	8	8	5.8	100	200	E2
ACS255-03U-09A5-4	5	11.5	9.2	16	15	8	8	9.5	100	100	E2
ACS255-03U-14A0-4	7.5	17.2	14.5	25	25	8	8	14	100	100	E3
ACS255-03U-18A0-4	10	21.2	17.2	32	30	8	8	18	100	50	E3
ACS255-03U-24A0-4	15	27.5	22	40	35	8	8	24	100	40	E3
ACS255-03U-30A0-4	20	34.2	24.8	40	45	16	5	30	100	22	E4
ACS255-03U-39A0-4	25	44.1	34	50	60	16	5	39	100	22	E4
ACS255-03U-46A0-4	30	51.9	40	63	70	16	5	46	100	22	E4

*Internal Braking transistor only available on drives with "+D150" in the model type designation (see section 3.3).

Note For UL compliance, Motor Cable to be 75°C Copper.

Note Other fuse types can be used if they meet the ratings and the melting curve of the fuse does not exceed the melting curve of the fuse mentioned in this table.

12.3. Overload

The ACS255 can deliver 150% of the drive nominal output current for 60 seconds and 175% for 2 seconds.

12.4. Additional Information for UL Compliance

ACS255 is designed to meet the UL requirements. In order to ensure full compliance, the following must be fully observed.

- For an up to date list of UL compliant products, please refer to UL listing NMMS.E211945
- The drive can be operated within an ambient temperature range as stated in section 12.1
- For IP20 units, the drive must be installed in a cabinet to fulfil the requirements for shielding from contact and environment contamination.
- For IP66 units, indoor installation in an environment free from icing and condensation.
- UL Listed ring terminals / lugs must be used for all bus bar and grounding connections.

Input Power Supply Requirements				
Supply Voltage	110-115 Volts RMS for 110 Volt rated drives, + /- 10% variation allowed.			
	200 – 240 Volts RMS for 230 Volt rated drives, + /- 10% variation allowed.			
	380 – 480 Volts RMS for 400 Volt rated drives, + / - 10% variation allowed.			
Imbalance	Maximum 3% voltage variation between phase – phase voltages allowed			
	All ACS255 units have phase imbalance monitoring. A phase imbalance of > 3% will result in the drive tripping. For input supplies which have supply imbalance greater than 3% (typically the Indian sub- continent & parts of Asia Pacific including China) ABB recommends the installation of input line reactors.			
Frequency	50 – 60Hz + / - 5% Variation			
Short Circuit Capacity	Voltage Rating	Min HP	Max HP	Maximum supply short-circuit current
	115V	0.5	1.5	100kA rms (AC)
	230V	0.5	5	100kA rms (AC)
	400 / 460V	0.5	10	100kA rms (AC)
All the drives in the above table are suitable for use on a circuit capable of delivering not more than the above specified maximum short-circuit Amperes symmetrical with the specified maximum supply voltage.				
Incoming power supply connection must be according to section 5.3				
All ACS255 units are intended for indoor installation only and within controlled environments which meet the condition limits shown in section 12.1				
Branch circuit protection must be installed according to the relevant national codes. Fuse ratings and types are shown in section 12.2				
Suitable Power and motor cables should be selected according to the data shown in section 12.2				
Power cable connections and tightening torques are shown in section 4.				
ACS255 provides motor overload protection in accordance with the National Electrical Code (US).				
<ul style="list-style-type: none"> • Where a motor thermistor is not fitted, or not utilized, It is recommended that the Thermal Overload Memory Retention is enabled by setting 3005 THERMAL OVERLOAD VALUE RETENTION = 1 • Where a motor thermistor is fitted and connected to the drive, connection must be carried out according to the information shown in section 10.6. 				

12.5. Derating Information

Derating of the drive maximum continuous output current capacity is required when

- Operating at ambient temperature in excess of 40°C / 104°F.
- Operating at Altitude in excess of 1000m/ 3281 ft.
- Operation with Effective Switching Frequency higher than the minimum setting.

The following derating factors should be applied when operating drives outside of these conditions.

12.5.1. Derating for Ambient Temperature

Enclosure Type	Maximum Temperature Without Derating. (UL Approved)	Derate by	Maximum Permissible Operating Ambient Temperature with Derating (Non UL Approved)
IP20	50°C / 122°F	N/A	50°C
IP66	40°C / 104°F	2.5% per °C (1.8°F)	50°C

12.5.2. Derating for Altitude

Enclosure Type	Maximum Altitude Without Derating	Derate by	Maximum Permissible (UL Approved)	Maximum Permissible (Non-UL Approved)
IP20	1000m / 3281ft	1% per 100m / 328 ft	2000m / 6562 ft	4000m / 13123 ft
IP66	1000m / 3281ft	1% per 100m / 328 ft	2000m / 6562 ft	4000m / 13123 ft

12.5.3. Derating for Switching Frequency

Enclosure Type	Switching Frequency (Where available)					
	4kHz	8kHz	12kHz	16kHz	24kHz	32kHz
IP20	N/A	N/A	20%	30%	40%	50%
IP66	N/A	10%	25%	35%	50%	50%

12.5.4. Example of applying Derating Factors

A 5Hp, 400V/460V IP66 drive is to be used at an altitude of 2000 meters above sea level, with 12kHz switching frequency and 45°C ambient temperature.

From the table above, we can see that the rated current of the drive is 9.5 Amps at 40°C,

Firstly, apply the switching frequency derating, 12kHz, 25% derating
 $9.5 \text{ Amps} \times 75\% = 7.1 \text{ Amps}$

Now, apply the derating for higher ambient temperature, 2.5% per °C above 40°C = $5 \times 2.5\% = 12.5\%$
 $7.1 \text{ Amps} \times 87.5\% = 6.2 \text{ Amps}$

Now apply the derating for altitude above 1000 meters, 1% per 100m above 1000m = $10 \times 1\% = 10\%$
 $7.9 \text{ Amps} \times 90\% = 5.5 \text{ Amps continuous current available.}$

If the required motor current exceeds this level, it will be necessary to either

- Reduce the switching frequency selected
- Use a higher power rated drive and repeat the calculation to ensure sufficient output current is available.

12.6. Mains Line input Reactors

An optional Line reactor is recommended to be installed on drives where any of the following site conditions occur:-

- The incoming supply impedance is low or the fault level / short circuit current is high.
- If the transformer kVA rating is more than 10x the kVA rating of the drive or ensure that the per drive source Impedance is less than 0.5%.
- The supply is prone to dips or brown outs.
- An imbalance exists on the supply (3 phase drives).
- The power supply to the drive is via a busbar and brush gear system (typically overhead Cranes).
- Reduction in Harmonics generated by the drive.

In all other installations, it is good practice to install a line reactor as added protection of the drive against power supply faults.

12.6.1. Selecting a Line Reactor

The chosen Line reactor should be in the region of 3% impedance; higher values can be used but will result in less voltage (and less torque) to the motor as full load is reached.

The continuous current rating should be at least the value of the drives input current rating, with a peak current rating of at least 2 times the continuous current rating.

CAUTION: Due to the low harmonic film capacitor design, the use of input reactors is not recommended with the E4 frame drives!

13. Appendix: Permanent magnet synchronous motors (PMSMs)

With PMSMs special attention must be paid on setting the motor nominal values correctly in parameter group 99 START-UP DATA. It is important that the nominal back-emf of the motor is available, further to ensure good performance a MOTOR PARAMETER AUTO-TUNE (9910=1) must be performed.

The following table lists the basic parameter settings needed for permanent magnet synchronous motors.

13.1. PMSM Motor nameplate data entry.

Action		Additional Information
<input type="checkbox"/> Enable PMSM motor control	Set 9903 to 2	
<input type="checkbox"/> Enter motor back-EMF voltage value	Enter Back EMF value into 9905	The phase to phase value (at motor rated Speed) should be obtained from the motor nameplate or datasheet. If the voltage is given as a proportional value, such as 103V/1000 rpm in a 3000rpm motor, set 309V here. Sometimes the value is given as the peak value. In this case divide the value by the square root of 2 (1.41). Note: Incorrect value can result in abnormal motor operation (motor vibration)
<input type="checkbox"/> Enter Motor Rated Current	Enter value into 9906	Obtained from Motor nameplate (Amps).
<input type="checkbox"/> Enter Motor Rated Frequency	Enter value into 9907	Note : The drive uses 9907 to calculate the number of motor pole pairs. Frequency (Hz) = speed (rpm) x (number of pole pairs) / 60
<input type="checkbox"/> Enter Motor Rated Speed	Enter value into 9908	Obtained from Motor nameplate (rpm) Speed (rpm) = frequency (Hz) x 60 / (number of pole pairs)
<input type="checkbox"/> Set Motor Switching Frequency	Set 2606 to 16kHz	16kHz provides optimum motor control.

13.2. PMSM Motor Auto-tune.

A Motor Auto-tune must be carried out in order to measure the motor electrical characteristics.

Action		Additional Information
<input type="checkbox"/> Enable Motor Auto-tune	Set 9910 to a <u>1</u> and press the  button.	The display will show Auto-t . Once the Auto-tune is completed 9910 will return to 0 and the display will show StoP . Note: Motor Auto-tune will need to be repeated if the motor, motor cables, motor parameters or drive control mode is changed in 9903 .

13.3. Troubleshooting

Observation	Action
Poor torque performance at low speed/poor motor start-up	Increase value in 2603 (Boost current level)
Motor Vibration/ F000 I trips/Cogging at low speed	Check correct settings of motor nameplate data. Check correct value of 9905 (Motor Back EMF voltage). Reduce value of 2301 (Vector Speed Gain)(As much as 50% reduction in some instances)
F0009	Check correct settings of motor nameplate data. Check correct value of 9905 (Motor Back EMF voltage). Check Correct setting of 2603 (Boost current level)
	Care should be taken not to apply to high of a value in 2603 (Boost current level) as excess motor heating may result.

14. Trouble Shooting

14.1. Fault Code Messages

Fault Code	No.	Description	Corrective Action
StoP	Ox00	Drive is READY and in a stopped condition. The motor is not energized. No enable signal is present to start the drive	
P-DEF	OX0A	Factory Default parameters have been loaded	Press the STOP key, drive is ready to configure for particular application
F0001	Ox03	Instantaneous Over current on the drive output. Excess load or shock load on the motor.	Fault occurs immediately on drive enable or run command Check the output wiring connections to the motor and the motor for short circuits phase to phase and phase to earth. Fault occurs during motor starting Check the motor is free to rotate and there are no mechanical blockages. If the motor has a brake fitted, check the brake is releasing correctly. Check for correct star-delta motor wiring. Ensure the motor nameplate current is correctly entered in parameter 9906 . Increase acceleration time in parameter 2202 . Reduce motor boost voltage setting in parameter 2603 Fault occurs when motor operating at constant speed Investigate overload. Fault occurs during motor acceleration or deceleration The accel/decel times are too short requiring too much power. If parameter 2202 or 2203 cannot be increased, a bigger drive may be required
F0009	Ox04	Motor thermal overload protection trip. The drive has tripped after delivering >100% of value in 9906 for a period of time to prevent damage to the motor.	Ensure the correct motor nameplate current value is entered in parameter 9906 . Check for correct Star or Delta wiring configuration. Check to see when the decimal points are flashing (which indicates the output current > parameter 9906 value) and either increase acceleration ramp (parameter 2202) or decrease motor load. Check the total motor cable length is within the drive specification. Check the load mechanically to ensure it is free, and that no jams, blockages or other mechanical faults exist
Ol-b	Ox01	Brake channel over current (excessive current in the brake resistor)	Check the cabling to the brake resistor and the brake resistor for short circuits or damage. Ensure the resistance of the brake resistor is equal to or greater than the minimum value for the relevant drive shown in the table in section 12.2
OL-br	Ox02	Brake resistor thermal overload. The drive has tripped to prevent damage to the brake resistor	Only occurs if parameter 2020 = 1. The internal software protection for the brake resistor has activated to prevent damage to the brake resistor. Increase the deceleration time (parameter 2203) or 2 nd deceleration time (parameter 2206). Reduce the load inertia For Other Brake Resistors Ensure the resistance of the brake resistor is equal to or greater than the minimum value for the relevant drive shown in the table in section 12.2. Use an external thermal protection device for the brake resistor. In this case, parameter 2020 may be set to 2
F0004 H O-I	Ox05	Hardware Over Current	Check the wiring to motor and the motor for phase to phase and phase to earth short circuits. Disconnect the motor and motor cable and retest. If the drive trips with no motor connected, it must be replaced and the system fully checked and retested before a replacement unit is installed.
F0002	Ox06	Over voltage on DC bus	Check the supply voltage is within the allowed tolerance for the drive. If the fault occurs on deceleration or stopping, increase the deceleration time in parameter 2203 or install a suitable brake resistor and activate the dynamic braking function with parameter 2020
F0006	Ox07	Under voltage on DC bus	The incoming supply voltage is too low. This trip occurs routinely when power is removed from the drive. If it occurs during running, check the incoming power supply voltage and all components in the power feed line to the drive.
F0003	Ox08	Heatsink over temperature	The drive is too hot. Check the ambient temperature around the drive is within the drive specification. Ensure sufficient cooling air is free to circulate around the drive. Increase the panel ventilation if required. Ensure sufficient cooling air can enter the drive, and that the bottom entry and top exit vents are not blocked or obstructed.
U-t	Ox09	Under temperature	Trip occurs when ambient temperature is less than -10°C. The temperature must be raised over -10°C in order to start the drive.
F0018	Ox10	Faulty thermistor on heatsink.	Refer to your local ABB representative
O-HEAT	Ox17	Drive internal temperature too high	Drive ambient temperature too high, check adequate cooling air is provided
F0014	Ox0B	External trip (on digital input 3)	E-trip requested on control input terminals. Some settings of parameter 9902 DIGITAL INPUTS FUNCTION SELECT require a normally closed contactor to provide an external means of tripping the drive in the event that an external device develops a fault. If a motor thermistor is connected check if the motor is too hot.
F0010	Ox0C	Comms loss trip	Check communication link between drive and external devices. Make sure each drive in the network has its unique address.
F0022	Ox0E	Input phase loss trip	Drive intended for use with a 3 phase supply has lost one input phase.
SPI-r-F	Ox0F	Spin start failed	Spin start function failed to detect the motor speed.
F0027	Ox11	Internal memory fault.	Parameters not saved, defaults reloaded. Try again. If problem recurs, refer to your local ABB representative
F0007	Ox12	Analog input current out of range	Check input current in range defined by parameter 1300 .
F0021	-	Internal drive Fault	Refer to your local ABB representative
FAULT4	-	Internal drive Fault	Refer to your local ABB representative
REF-01	40	Autotune Fault	Measured motor stator resistance varies between phases. Ensure the motor is correctly connected and free from faults. Check the windings for correct resistance and balance.
REF-02	41		Measured motor stator resistance too large. Ensure motor is correctly connected and free from faults. Check that the power rating corresponds to the power rating of the connected drive.
REF-03	42		Measured motor inductance too low. Ensure the motor is correctly connected & free of faults.
REF-04	43		Measured motor inductance is too large. Ensure the motor is correctly connected and free from faults. Check that the power rating corresponds to the power rating of the connected drive.
REF-05	44		Measured motor parameters are not convergent. Ensure the motor is correctly connected and free from faults. Check that the power rating corresponds to the power rating of the drive.
SC-FDI	50	Modbus comms loss fault	Check the incoming Modbus RTU connection cable. Check that at least one register is being polled cyclically within the timeout limit set in 5302 Index 3
.StoP .	-	Stop is displayed with flashing dots	Check power and motor connections. Indicates cross connection.



3AXD10001010247